

Bermuda™ Railing System by Monarch™ (Traditional or Colonial Balusters)

Prior to Installation



1 Picking the right kit for your application

First floor application	Second floor application
36" H X 72" L	42" H X 72" L
36" H X 96" L	42" H X 96" L

Bermuda™ composite railing system by Monarch™ is first to meet ICC-ES #1085 acceptance criteria and approval

ICC-ES ensures that building products meet code requirements (ICC-ES.org)



2 Post sleeve kits and accessories sold separately

Bermuda™ composite post sleeves come two 4' units per kit. Bermuda assorted post caps and post skirt bases are sold separately (see your local dealer for selection).

Note: If deck, porch and/or stairs do not include existing 4" X 4" posts, use Monarch™ metal post supports, sold separately. See installation guide #10, 10A & 10B.

3 Bermuda™ railing kit by Monarch™

Review all contents of your Bermuda railing kit prior to starting your railing project—if missing any pieces—please contact Monarch at 1-877-666-2742

- 1 Hand rail
- 1 Bottom rail
- 1 Pre-drilled retainer
- 1 Support block
- 1 Support block retainer
- 13 Balusters (6' kit)
- 18 Balusters (8' kit)
- 1 Hardware kit (see below)



Hardware kit contents:

(18) 1½" - #8 wood screws for attaching balusters; (18) 3" - #8 wood screws for attaching balusters to bottom rail; (8) ¼" X 1½" lag bolts for attaching bracket to posts; (8) 1 ⅛" - #8 stainless wood screws for attaching brackets to retainer and brackets to bottom rail; (8) washers for use with the 1 ⅛" - #8 stainless wood screws; (3) ¾" - #8 stainless wood screws for fastening/ securing the top rail /retainer assembly; (3) 1" - #8 stainless wood screws for fastening center support to 4" flat center support bracket and 4" flat bracket to bottom rail; (4) 'L' brackets; (1) 4" flat bracket; (8) plastic lag bolt head caps.

PRIOR TO INSTALLATION

4 Take measurements to assure proper post heights

Prior to installing the post sleeves, confirm the height needed for your 4" X 4" pressure-treated post, based on your desired overall rail height. Remember to include the post cap, and post skirt base as part of the equation for post heights. To ensure proper cap attachment, make sure the pressure treated 4" X 4" post is at least 1" below the top of the sleeve.



Note: To ensure proper cap attachment, make sure pressure treated 4" X 4" post is at least 1" below the top of the sleeve.

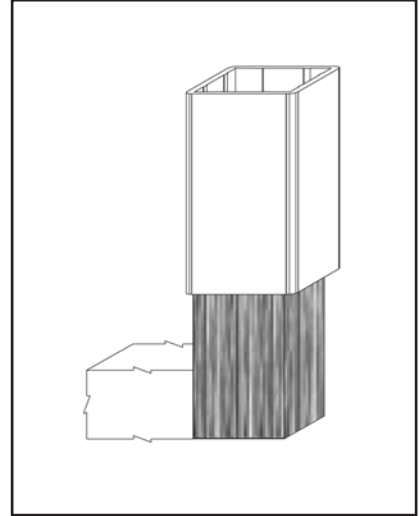

5 Cutting rails to length: Take time to measure and avoid ruining handrail material

TAKE YOUR TIME, and plan your cuts. Use a pencil to mark the cuts on the horizontal railing parts. Make marks on masking tape if you prefer, because composite doesn't mark easily. Set the end balusters in place and test to be sure the mounting brackets will fit in the remaining space.

For example: suppose you needed to cut 7" from a section of handrail. You could just cut 3 1/2" from each end of the retainer and the bottom rail. But that would leave only a half inch of rail between the last baluster and the end of the rails. That does not leave enough room to attach the mounting bracket. The solution is to shorten the handrail by a full baluster interval, (or just a bit less) and then trim an equal amount from each end.

The **right way** to shorten a section of railing by 7" would be to first cut one full baluster interval from the retainer and bottom rail (that's 5 1/4 inches), and then remove the remaining amount (1 3/4") by cutting half that length (7/8") from each end. That would leave 3 1/8" of open space at each end of the railing section... well within the code-required maximum of 4" and still big enough to look similar to spacing between balusters.

Important Safety Note: The 4" maximum between balusters is determined by building codes, and is meant to prevent little children from getting their heads stuck between balusters.

To be sure there is enough room to attach the brackets, leave at least two inches from the end of the rail to the side of the baluster. Since each baluster is about 1 1/4" wide, that's a **minimum** of 2 5/8" from the end of the rail to the center of the baluster screw hole. **Be careful and check your measurements and calculations several times if necessary. With handrails it's easy to make mistakes.**

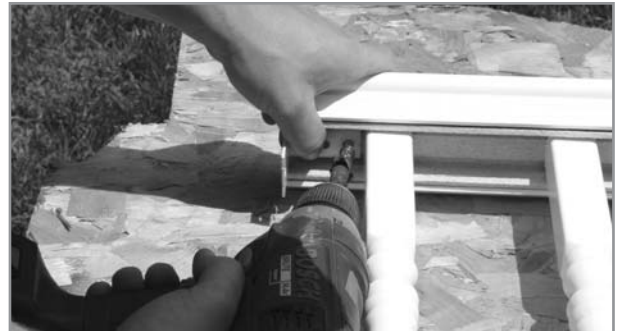

Bermuda™ Railing System by Monarch™ (Traditional or Colonial Balusters) Installation Guide

Bermuda™ Railing
Components

See "Prior to Installation"
Information for Measuring tips
and to Review Kit Contents



1 Installing the post sleeves

The Monarch™ Bermuda™ post sleeve is designed to slide over a pressure treated 4" X 4", (the 4" X 4" post should extend to the bottom of the rim joist and be attached to the joist). Ensure the sleeve is plumb and rises to the proper height. Using a 5/16" carbide tipped drill bit, pre-drill two holes each at the base on the two opposite sides from where the rail attaches. Proceed to fasten the post sleeve to the 4" X 4" with (2) 3" – #8 stainless wood screws (provided in kit). (Figure #1)



Note: If optional post skirt base is used, install prior to installing railing.

Note: If your application does not make use of posts, use Monarch™ metal post supports, sold separately. See steps 10, 10A and 10B.

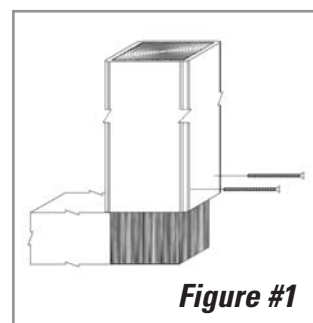

Figure #1

See "Prior to Installation"
information for measuring tips.



2 Railing measurements

Measure the distance between the post sleeves to determine the length of the railing. Be sure to measure both the top rail and the bottom rail distance as they may not be equal. Measure the top rail/retainer from its centerpoint. Trim each end of the top rail/retainer equally while maintaining the correct overall length. Repeat these steps for the bottom rail using the bottom rail measurement determined previously.

Note: Due to variation in length of the top rail, retainer and bottom rail – it may be necessary to cut off differing amounts from each rail to have all three rails evenly fit between the posts.

INSTALLATION GUIDE



Note: Installation photos show Bermuda™ all white railing kits with colonial balusters.

3 Baluster assembly

Place the retainer on a clean flat surface. Align the end of each baluster with the pre-drilled holes in the retainer and bottom rail. Using the 1 1/2" - #8 stainless steel wood screws (provided), fasten the balusters to the retainer and bottom rail through the pre-drilled holes. (Figure #2)

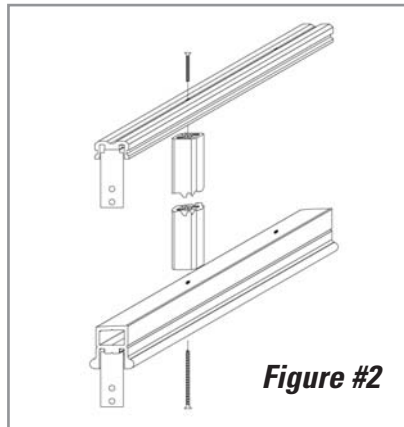

Figure #2

Note: Take time to set up a proper working surface as shown to the left (two saw horses and a sheet of plywood), it will make set up of the Bermuda™ railing systems more manageable and save installation time.

4 Top rail assembly

Slide the handrail over the retainer. Once the handrail is in place, fasten the handrail to the retainer through the pre-drilled holes in the retainer, using the 3/4" - #8 stainless wood screws. This should result in a secure fit between the top rail and the retainer. (Figure #3)

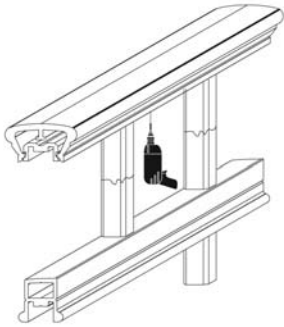

Figure #3

5 Bracket assembly

Place the bracket on the underside of each end of the retainer and bottom rail. Align the edge of the bracket 1/16" outside of each profile to allow for expansion. Fasten the mounting brackets to the underside of the retainer and bottom rail using the #8 - 1 1/8" stainless steel screws and washers (provided). Make sure the brackets are straight and extend 1/16" outside the end of each profile. Remember to use washers with each screw. (Figure #4)

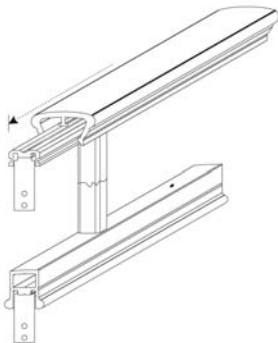

Figure #4



Installing top bracket onto retainer after installing balusters and top rail.



Installing bottom rail bracket prior to installing balusters.

6 Rail system post sleeve alignment

To establish the proper height of the railing from the surface of the deck, place the railing assembly into the opening between the post sleeves resting it on two, 2" X 4" spacers on edge (i.e., 3 1/2" high). Be certain the lip on the bottom rail is to the outside of the deck, porch and/or stair project. Make sure the assembled railing is plum and square, then mark the bracket holes on the post sleeves. Remove the railing and drill pilot holes in the post sleeves using a 5/16" carbide tipped drill bit. (Figure #5)

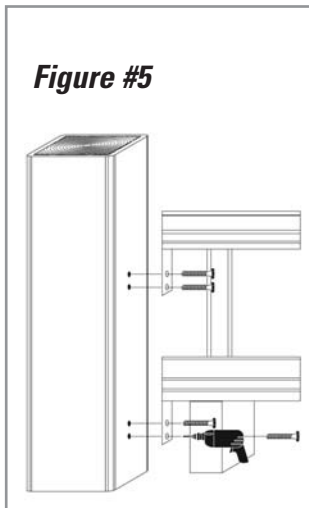

Figure #5

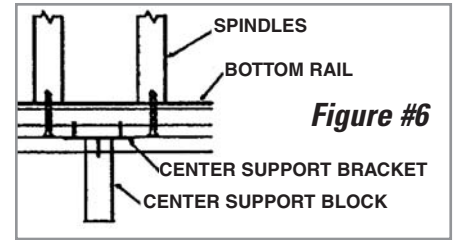

Figure #6

Note: To ensure your desired rail height, measure the distance at the centerpoint of the rail section, from the inside bottom rail to the deck for the support block installation.

7 Support block installation

Fasten the 4" flat stainless steel bracket to the 6" support block using a 1" - #8 stainless wood screw (provided). Once the support block is mounted to the center hole of the flat bracket, trim the support block to the correct length. Now, mount the support block/flat bracket assembly to the underside of the bottom rail. Determine the center point of the bottom rail and pre-drill holes using the two outside holes on the flat bracket as a guide. Fasten flat bracket using two remaining 1" - #8 stainless wood screws. (Figure #6)

Note: Prior to setting completed rail in place make two 2" X 4" (on edge will be 3 1/2" tall) supports from scrap wood to make installation easy, using one on each side of the center support block to support the entire rail while screwing into place.

Note: If you're using post skirt bases, be sure they are installed prior to installing the completed rail.

8 Attaching rail to post sleeve

We are now going to mount the railing assembly to the posts. Place the railing section back into the opening and attach the railing to the posts with the 1/4" X 1 1/2" lag bolts supplied. Use a 7/16" X 1/4" drive socket or 7/16" ratchet wrench, which works best. When completed, install the eight (8) plastic caps on the heads of exposed lag bolts.

9 Fastening post cap to post sleeve

Once the rail has been completely installed, apply the desired post cap. Place a generous bead of 100% silicone exterior-grade caulking on the end of the sleeve. Place the cap firmly onto the caulking, centering it over the sleeve. Allow caulking to set for 24 hours. (Figure #7)

Note: Prior to installing the post cap, review "Prior to Installation" information to make sure you have left the proper space for proper seating of post caps.

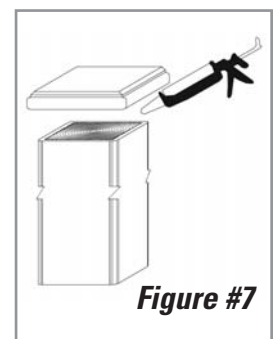

Figure #7

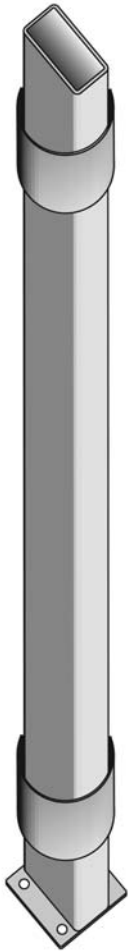

Figure #8

10 Monarch™ post supports available for existing decks

Monarch™ offers metal post supports (sold separately) that can be used for wood or concrete decks, porches, patios, docks and/or stairs. They are installed easily – simply bolt to an existing surface, using 5/16" concrete anchors or 5/16" lag bolts or carriage bolts, depending on application. (Figure #8)



10 A Concrete application (surface mount)

Layout post supports for proper alignment. With all supports facing the same direction, mark the 4 holes for drilling. Drill the 4 holes in the concrete for a 5/16" concrete anchor bolt (see your local supplier for proper hardware). Cut the Monarch post sleeve to proper length and install over the Monarch post support.

Note: Make sure Monarch™ post supports are facing the same way for all applications. Double check your layouts before drilling holes.

10 B Wood application (surface mount)

Layout post supports for proper alignment, trace the 4 holes from the bottom support plate prior to drilling the 4 holes in the deck. Use a 5/16" lag, screw or carriage bolts (see your local supplier for proper hardware). Depending on application, some reinforcement of the deck may be necessary. Cut the post sleeve to proper length and install over the post support.

Note: Reinforce from joist to joist on the under side of the existing structure to insure sufficient strength to support railing system.

Note: Some applications may require metal lag screws to install the Monarch™ metal post support. See your local supplier for proper hardware.

