



Power Joist™

User guide
(ICC ESR-1262)

Table of Contents

1	Joining Forces
2	APA Performance Rated™ I-Joists
3	Storage and Handling Guidelines, Safety Precautions
4	Selecting ADI Power Joist
5	Allowable Floor Spans
6	Allowable Floor Uniform Load Capacities — ADI 40
7	Allowable Floor Uniform Load Capacities — ADI 60 & 80
8-11	Floor Framing and Construction Details
12	Cantilever Details for Balconies
13	Cantilever Details for Vertical Building Offset
14	Cantilever Reinforcement Methods
15	Web Hole Rules and Specifications
16	Web Hole Specifications
17-18	Rim Board, Hole Specification
19-22	Roof Framing and Construction Details
23-25	Allowable Roof Spans — Simple and Multiple
26	Allowable Roof Uniform Load Capacities — ADI 40
27	Allowable Roof Uniform Load Capacities — ADI 60
28	Allowable Roof Uniform Load Capacities — ADI 80
29	Multiple Power Joist Construction, Power Joist Web Stiffeners
30	Power Joist Design Properties
31	Certified Rim Boards
32	Power Joist Framing Connectors
33	Anthony Power Sizer & Power Products Warranty



Joining Forces



Anthony Forest Products Company and Domtar Inc. have formed a joint venture to manufacture and distribute **Power Joist™**, a high quality solid lumber flange I-joist. This value-added product upholds Anthony's and Domtar's commitment to using lumber to its highest strength potential, while also offering an environmentally sound alternative to large dimension lumber joists. In addition to our financial contribution to the 50-50 partnership, Anthony and Domtar bring unique skills to the venture. Domtar contributes its expertise in mill management, along with a reliable supply of MSR lumber. Anthony adds its renowned customer service infrastructure, **Superior Power Products** and nationwide distribution network.

About the Partners

Anthony Forest Products Company, a family-owned business founded in 1916, is headquartered in El Dorado, Arkansas. The company operates lumber and wood chip mills, as well as two engineered wood laminating plants in the southern US. It has 35 years of solid experience in engineered wood products.

Domtar is the third largest producer of uncoated freesheet paper in North America. It is also a leading manufacturer of business papers, commercial printing and publication papers, and technical and specialty papers. Domtar manages according to internationally recognized standards, 22 million acres of forestland in Canada and the United States, and produces lumber and other wood products. Domtar has 11,000 employees across North America. The company also has a 50% investment interest in Norampac Inc., the largest Canadian producer of containerboard.



Environmental Forestry

Domtar management practices are designed to pass on healthy forests to future generations. In this context, independent third-party verification of its forest management practices is one of Domtar's forest policy commitments. All forest lands that Domtar manages directly will soon be certified according to internationally recognized environmental standards, such as ISO 14001 and the Forest Stewardship Council (FSC).

The Joint-Venture Plant

This new state-of-the-art, high efficiency, one piece flow facility is located in Sault Ste. Marie, Ontario, Canada. This strategically located plant provides fast and efficient access to the entire North American market.



The Power Joist™

The solid lumber flange I-joist is made from 2x3 and 2x4 MSR lumber.

Power Joist™ is the latest addition to the Superior Power Products line, which includes Power Beam®, Power Header®, Power Plank®, Power Log®, and Power Column®.

Anthony-Domtar Inc.'s power-of-two venture is a combination that brings more choices, more value and more power... to the customer.

APA Performance Rated™ I-Joists

Say What They Do and Do What They Say

APA – The Engineered Wood Association has made it easy to make the right choice for residential floor and roof joist products. ADI Power Joists are produced in accordance with the APA’s PRI-400 standard, APA EWS report ICC ESR – 1405 and Anthony – Domtar’s report ICC ESR – 1104. All code reports can be downloaded from www.anthonyforest.com.

APA Performance Rated™ I-Joists (PRI™) provide a high performance alternative to dimension lumber joists for residential floor applications. This guide will help you efficiently use ADI Power Joist by leading you through the simple steps of product selection, specification, and installation.

The APA trademark signifies that the I-joist manufacturer is committed to the strict quality standards of Engineered Wood Systems (EWS), a related corporation of APA, and that ADI’s are manufactured in conformance with PRI-400, Performance Standard for APA EWS I-Joists. APA’s rigorous program of quality verification and testing is designed to assure predictable product performance.

PRI-400 brings product standardization while providing for a multitude of design and construction situations. The standard provides design information for numerous types and sizes of I-joists. Because ADIs can be selected based on their allowable span for glued uniformly loaded residential floors, it is easy to incorporate them into your design.

This guide explains residential floor and roof systems. Review by a design professional is required for applications beyond the scope of this document. Simple to specify. Easy to install. Less confusion. ADI Power Joists are the right choice for residential floor and roof construction.

Power Joist Labeling Example

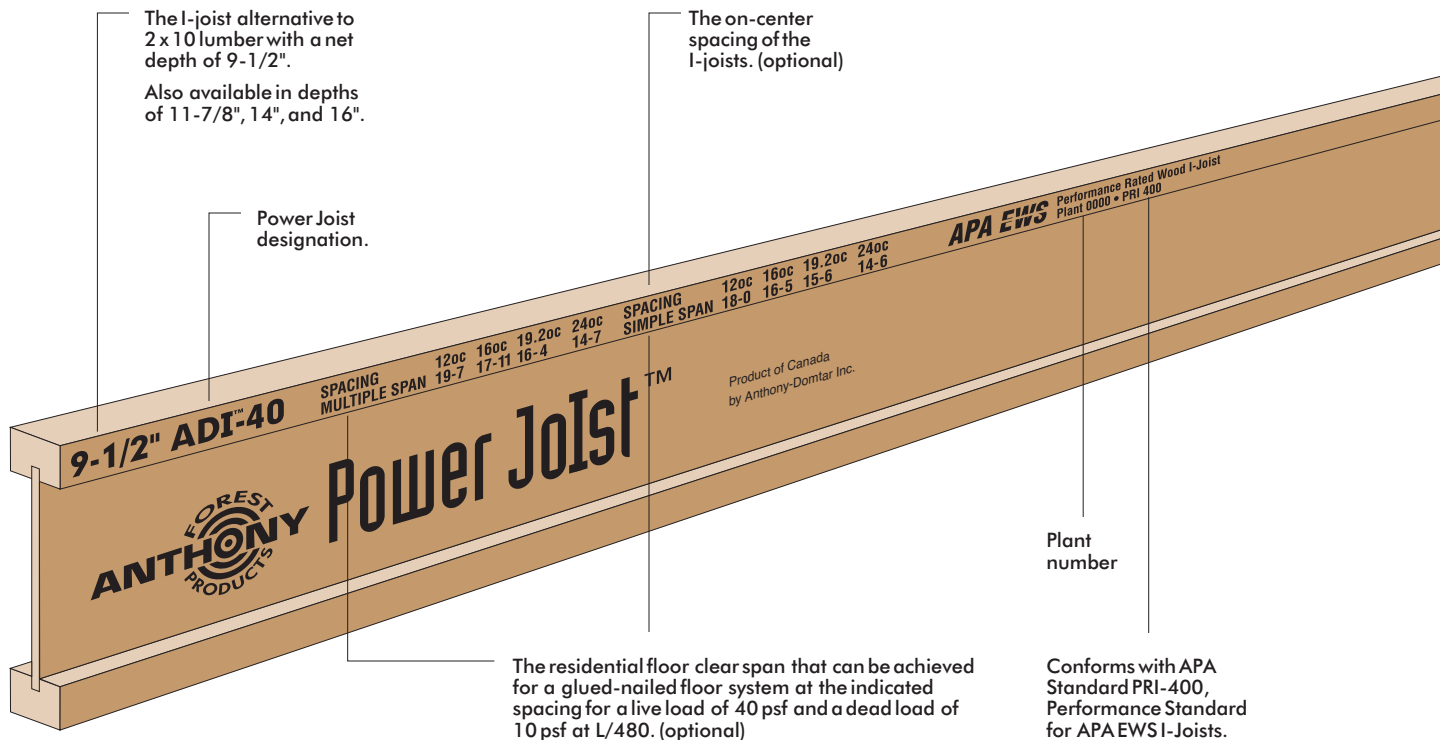

Storage and Handling Guidelines

1. Store Power Joists vertically, level and in bundles.
2. Always stack and handle Power Joists in the upright position only.
3. Do not store Power Joists in direct contact with the ground.
4. Protect Power Joists from weather, and use stickers to separate bundles.
5. Bundled units should be kept intact until time of installation.
6. When lifting Power Joists with a crane on the job site, take a few simple precautions to prevent damage to the Power Joists and injury to your work crew.
 - Pick Power Joists in bundles as shipped by the supplier.
 - Orient the bundles so that the webs of the Power Joists are vertical.
 - Pick the bundles at the 5th points, using a spreader bar if necessary.
7. Do not handle Power Joists in a horizontal orientation.
8. *Never* use or field repair a damaged Power Joist.

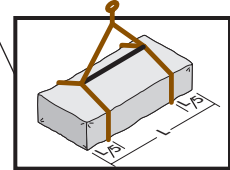
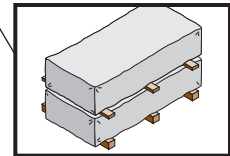
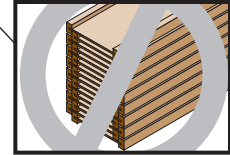
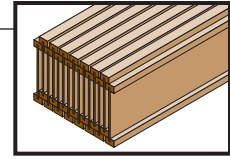

Safety Precautions

WARNING: Power Joists are not stable until completely installed and will not carry any load until fully braced and sheathed.

Avoid Accidents by Following These Important Guidelines:

1. Brace and nail each Power Joist as it is installed, using hangers, blocking panels, rim board and/or cross-bridging at joist ends.
2. When the building is completed, the floor sheathing will provide lateral support for the top flanges of the Power Joists. Until this sheathing is applied, temporary bracing, often called struts, or temporary sheathing must be applied to prevent Power Joist rollover or buckling.
 - Temporary bracing or struts must be 1 x 4 inch minimum, at least 8 feet long and spaced no more than 8 feet on center, and must be secured with a minimum of two 8d nails fastened to the top surface of each Power Joist. Nail bracing to a lateral restraint at the end of each bay. Lap ends of adjoining bracing over at least two Power Joists.
 - Or, sheathing (temporary or permanent) can be nailed to the top flange of the first 4 feet of Power Joists at the end of the bay.
3. For cantilevered Power Joists, brace top and bottom flanges, and brace ends with closure panels, rim board, or cross-bridging.
4. Install and nail permanent sheathing to each Power Joist before placing loads on the floor system. Then, stack building materials over beams or walls only.
5. *Never* install a damaged Power Joist.

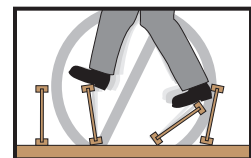

Do not allow workers to walk on Power Joists until joists are fully installed and braced, or serious injuries can result.

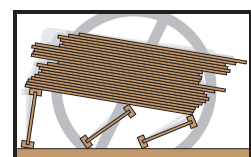

Never stack building materials over unsheathed Power Joists. Stack only over beams or walls.

Selecting ADI Power Joist™

Product Description

The ADI Power Joist is an “I”-shaped engineered wood structural member designed for use in residential floor and roof construction. ADI’s are prefabricated using SPF lumber flanges and OSB web, bonded together with exterior-type adhesives. It is recommended that Power Joists are limited to $L/480$ maximum live load deflection for residential floor applications, a criteria which provides superior floor performance. ADI Power Joists are identified by their depth followed by a designation such as ADI-40 which relates to the joist strength and stiffness.

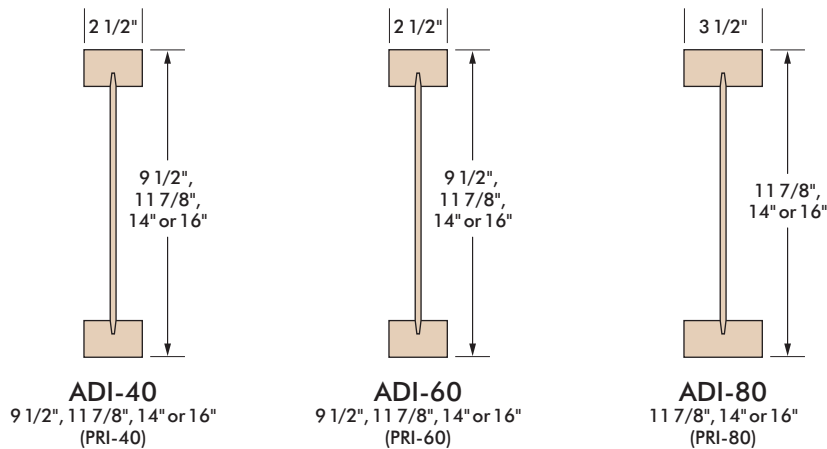

ADIs are manufactured to strict tolerances with the following characteristics:

- **Flanges** are MSR 2x3's and 2x4's.
- **Webs** are OSB and all are classified as Exposure 1 or Exterior and are 3/8" in thickness or greater.
- All ADIs are assembled using exterior-type adhesives per ASTM D 2559.
- ADIs are available in four depths: 9-1/2", 11-7/8", 14", and 16".
- ADIs of the same depth are manufactured with various flange widths; flange width is an important design consideration when specifying hangers.
- Most mills manufacture I-joists in lengths up to 48 feet in length. ADI Power Joists are manufactured up to 64 feet in length. These lengths are cut to frequently used lengths such as 16 to 36 feet, in 2-foot increments for jobsite delivery. Check local supplier for availability.

Allowable Floor Spans

Residential Floor Maximum Allowable Spans

The specific ADI designation needed for your application is easily determined by selecting the span needed and then choosing the ADI that meets your span, spacing, and uniform load- ing criteria.

Table 1 is for simple or multiple span applications respectively. The use of this table will provide maximum spans for the indicated spacings and span conditions.

To illustrate the selection of an ADI product, assume a design simple span of 16'1". For architectural reasons, limit the joist depth to 11-7/8" and joist spacing to 19.2" on center. From the 9-1/2" and 11-7/8" entries in Table 1, look down the 19.2" o.c. spacing column. For depths of 9-1/2", select 9-1/2" ADI-60, and from the 11-7/8" depths notice that any joist designation will work.

The allowable spans in the table in this user guide indicate the allowable clear span for various joist spacings under typical residential uniform floor loads (40 psf live load and 10 psf dead load) for glued-nailed systems.

The spans shown in Table 1 is based on repetitive member usage which is typical for all wood products spaced 24" on center or less. In addition, floor sheathing must be field glued using approved construction adhesives to the Power Joist flanges to achieve the ADI allowable spans.

Use of this span table is limited to uniform load conditions and ADI floor spans shall not exceed these allowable spans. ADI Power Joist can be used for other applications such as roofs and ceilings to support line loads or concentrated loads, etc., when properly engineered using the appropriate design properties in Table 21.

Joist Depth (inches)	Joist Designation	On Center Spacing - Simple Spans (inches)			
		12	16	19.2	24
9 - 1/2"	ADI-40	18'-0"	16'-5"	15'-6"	14'-6"
	ADI-60	18'-11"	17'-4"	16'-4"	15'-3"
11 - 7/8"	ADI-40	21'-5"	19'-7"	18'-6"	16'-8"
	ADI-60	22'-7"	20'-8"	19'-6"	18'-2"
	ADI-80	24'-11"	22'-8"	21'-4"	19'-10"
14"	ADI-40	24'-4"	22'-3"	20'-6"	18'-4"
	ADI-60	25'-9"	23'-6"	22'-2"	20'-8"
	ADI-80	28'-3"	25'-9"	24'-3"	22'-7"
16"	ADI-40	26'-11"	24'-3"	22'-1"	19'-9"
	ADI-60	28'-6"	26'-0"	24'-7"	22'-10"
	ADI-80	31'-4"	28'-6"	26'-10"	25'-0"

9-1/2"	ADI-40	19'-7"	17'-11"	16'-4"	14'-7"
	ADI-60	20'-8"	18'-10"	17'-9"	16'-6"
11-7/8"	ADI-40	23'-5"	20'-5"	18'-7"	16'-7"
	ADI-60	24'-8"	22'-6"	21'-2"	19'-7"
	ADI-80	27'-1"	24'-8"	23'-3"	21'-7"
14"	ADI-40	25'-11"	22'-5"	20'-5"	18'-3"
	ADI-60	28'-0"	25'-7"	24'-1"	19'-9"
	ADI-80	30'-10"	28'-0"	26'-5"	23'-11"
16"	ADI-40	27'-11"	24'-2"	22'-0"	19'-8"
	ADI-60	31'-1"	28'-4"	24'-9"	19'-9"
	ADI-80	34'-2"	31'-1"	29'-3"	23'-11"

SI: 1 inch = 25.4 mm, 1 foot = 304.8 mm, 1 psf = 47.88 Pa

- (1) Allowable clear span applicable to simple-span or multiple-span residential floor construction with a design dead load of 10 psf and a live load of 40 psf. The live load deflection is limited to L/480. (L = span length in inches)
- (2) Spans are based on a composite floor with glue-nailed sheathing meeting the requirements for APA Rated Sheathing STURD-I-FLOOR conforming to PS1 or PS2 with a minimum thickness of 19/32" (40/20 or 20 o.c.) for a joist spacing of 19.2 inches or less, or 23/32-inch (48/24 or 24 o.c.) for a joist spacing of 24 inches when floor sheathing is nailed only. Adhesive shall meet APA Specification AFG-01 or ASTM D3498. Spans shall be reduced to 12 inches when floor sheathing is nailed only.
- (3) Minimum bearing length shall be 1-3/4 inches for the end bearings and 3-1/2 inches for the intermediate bearings.
- (4) Bearing stiffeners are not required when I-joist are used with the spans and spacing given in the above table, except as required for hangers.

Allowable Floor Uniform Load Capacities

Table 2								
Floor ADI Power Joist — ADI 40								
Allowable Uniform Loads (PLF)								
CLEAR JOIST SPAN (ft.)	9-1/2"		11-7/8"		14"		16"	
	LIVE LOAD Defl. L/480	TOTAL LOAD Defl. L/240	LIVE LOAD Defl. L/480	TOTAL LOAD Defl. L/240	LIVE LOAD Defl. L/480	TOTAL LOAD Defl. L/240	LIVE LOAD Defl. L/480	TOTAL LOAD Defl. L/240
6		281		325		325		325
7		242		280		280		280
8		212		246		246		246
9		189		219		219		219
10		170		197		197		197
11	153	155		179		179		179
12	118	133		165		165		165
13	93	113		151		152		152
14	75	98	128	131		141		141
15	61	85	104	114		132		132
16	51	75	86	100		124		124
17	42	67	72	89	105	117		117
18	36	60	61	79	89	104		110
19	30	53	52	71	76	94		103
20	26	48	45	64	65	85	89	93
21		44	39	59	56	77	77	84
22		39	34	53	49	70	67	77
23		34	29	49	43	64	58	70
24		30	26	45	38	59	52	65
25		27		41	34	54	46	60
26				38	30	50	41	55
27				36	27	47	36	51
28				33		43	33	48
29				30		40	29	44
30				27		38	27	42
31						35		39
32						32		37
33						29		34
34						27		32

Notes for Table 2:

1. Live Load column limits deflection to L/480, Total Load column limits deflection to L/240.
2. Values represent the most restrictive of simple span or multiple span conditions.
3. Values are for I-joists spaced at a maximum of 24" on center.
4. Table assumes a minimum end bearing length of 1-3/4" and a minimum interior bearing length of 3-1/2".
5. Web stiffeners are not required at the bearing unless the joist hanger does not provide lateral support for the top flange of the I-joist.

Joist Sizing:

1. Select desired joist depth (column).
2. Select desired span (row).
3. Check BOTH Live Load and Total Load columns.
4. If Live Load column is blank, Total Load capacity governs.

Allowable Floor Uniform Load Capacities

Table 3								
Floor ADI Power Joist — ADI 60								
Allowable Uniform Loads (PLF)								
CLEAR JOIST SPAN (ft.)	9-1/2"		11-7/8"		14"		16"	
	LIVE LOAD Defl. L/480	TOTAL LOAD Defl. L/240	LIVE LOAD Defl. L/480	TOTAL LOAD Defl. L/240	LIVE LOAD Defl. L/480	TOTAL LOAD Defl. L/240	LIVE LOAD Defl. L/480	TOTAL LOAD Defl. L/240
6		281		325		325		325
7		242		280		280		280
8		212		246		246		246
9		189		219		219		219
10		170		197		197		197
11		155		179		179		179
12	141	142		165		165		165
13	112	131		152		152		152
14	90	122		141		141		141
15	73	114	125	132		132		132
16	60	104	103	124		124		124
17	51	92	86	117		117		117
18	43	82	73	110	107	110		110
19	36	73	62	98	92	104		104
20	31	62	53	89	79	99		99
21	27	54	46	81	68	95	93	95
22		47	40	74	59	90	81	90
23		41	35	67	52	83	71	86
24		36	31	62	46	76	63	83
25		32	28	55	41	70	55	80
26		29		49	36	65	49	76
27		26		44	32	60	44	71
28				39	29	56	40	66
29				35	26	52	36	61
30				32		47	32	57
31				29		43	29	54
32				26		39	27	50
33						36		47
34						32		44

Table 4						
Floor ADI Power Joist — ADI 80						
Allowable Uniform Loads (PLF)						
CLEAR JOIST SPAN (ft.)	11-7/8"		14"		16"	
	LIVE LOAD Defl. L/480	TOTAL LOAD Defl. L/240	LIVE LOAD Defl. L/480	TOTAL LOAD Defl. L/240	LIVE LOAD Defl. L/480	TOTAL LOAD Defl. L/240
6		359		393		393
7		309		338		338
8		271		297		297
9		241		264		264
10		218		238		238
11		198		217		217
12		182		199		199
13		168		184		184
14		156		171		171
15		146		160		160
16		137		150		150
17	119	129		141		141
18	101	122		133		133
19	86	115	125	126		126
20	74	110	108	120		120
21	64	104	93	114		114
22	56	100	81	109		109
23	49	95	71	104	97	104
24	43	86	63	100	85	100
25	38	76	56	96	76	96
26	34	68	50	92	67	92
27	30	60	44	85	60	89
28	27	54	40	79	54	86
29		49	36	72	49	83
30		44	32	65	44	80
31		40	29	59	40	76
32		36	27	53	36	71
33		33		49	33	66
34		30		45	30	61

Notes for Tables 3 and 4:

1. Live Load column limits deflection to L/480, Total Load column limits deflection to L/240.
2. Values represent the most restrictive of simple span or multiple span conditions.
3. Values are for I-joists spaced at a maximum of 24" on center.
4. Table assumes a minimum end bearing length of 1-3/4" and a minimum interior bearing length of 3-1/2".
5. Web stiffeners are not required at the bearing unless the joist hanger does not provide lateral support for the top flange of the I-joist.

Joist Sizing:

1. Select desired joist depth (column).
2. Select desired span (row).
3. Check BOTH Live Load and Total Load columns.
4. If Live Load column is blank, Total Load capacity governs.

Floor Framing and Construction Details

Figure 1

Typical ADI Power Joist™ Floor Framing and Construction Details

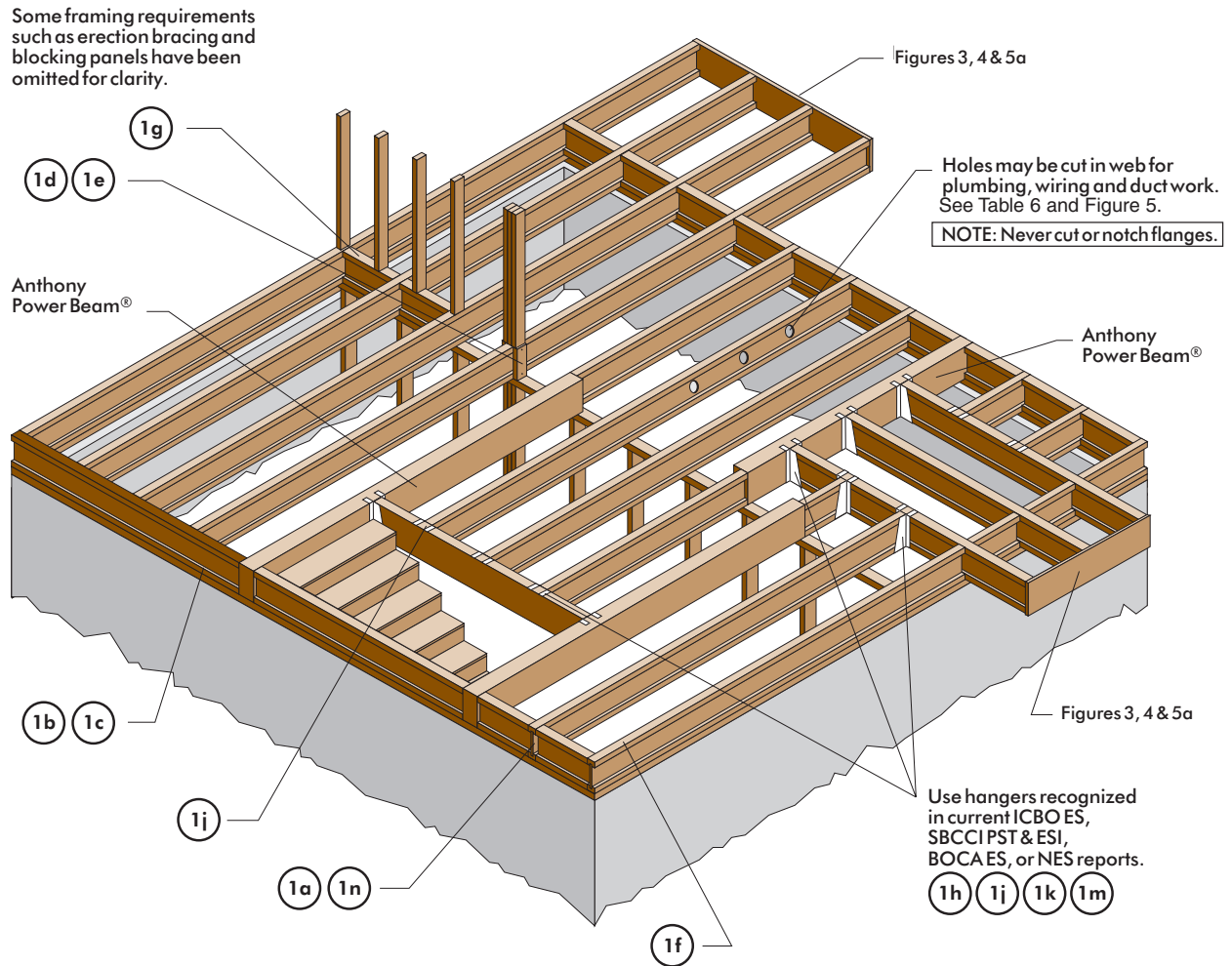

Figure 1 Continued

Typical ADI Power Joist™ Floor Framing and Construction Details

All nails shown in the details below are assumed to be common nails unless otherwise noted. 10d box nails may be substituted for 8d common shown in details. Individual components not shown to scale for clarity.

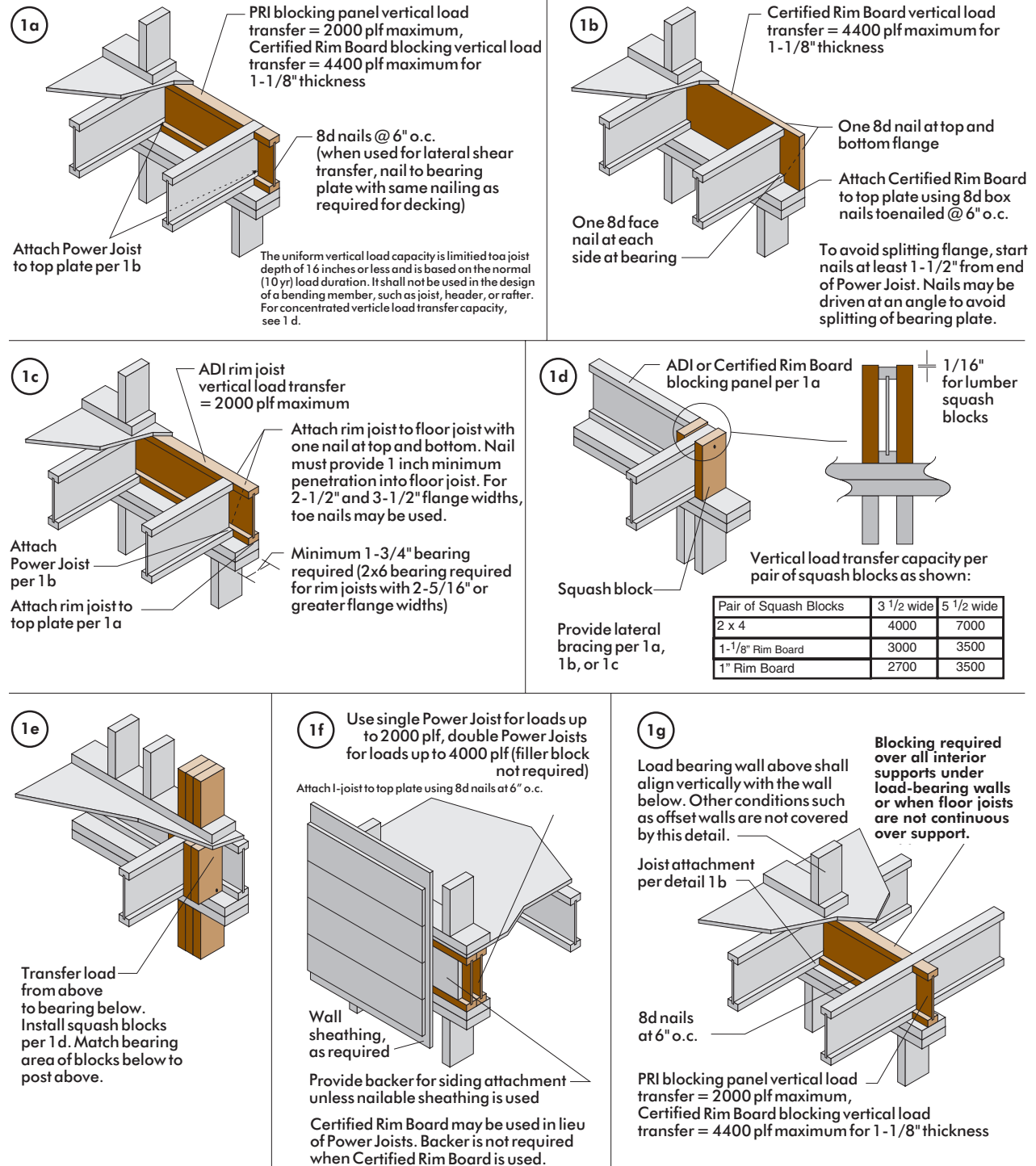

Figure 1 Continued

Typical ADI Power Joist™ Floor Framing and Construction Details

All nails shown in the details below are assumed to be common nails unless otherwise noted. 10d box nails may be substituted for 8d common shown in details. Individual components not shown to scale for clarity.

1h

Backer block (use if hanger load exceeds 250 lbs.) Before installing a backer block to a double Power Joist, drive 3 additional 10d nails through the webs and filler block where the backer block will fit. Clinch. Install backer tight to top flange. Use twelve 10d nails, clinched when possible. Maximum capacity for hanger for this detail = 1280 lb.

BACKER BLOCKS (Blocks must be long enough to permit required nailing without splitting)

Flange Width	Material Thickness Required*	Minimum Depth**
2-1/2"	1"	5-1/2"
3-1/2"	1-1/2"	7-1/4"

* Minimum grade for backer block material shall be Utility grade SPF or better for solid sawn lumber and Rated Sheathing grade for wood structural panels.

** For face-mount hangers use net joist depth minus 3-1/4" for joists with 1-1/2" thick flanges.

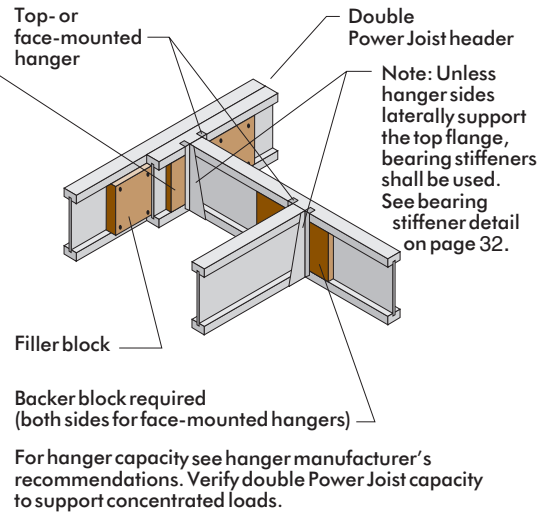

1j

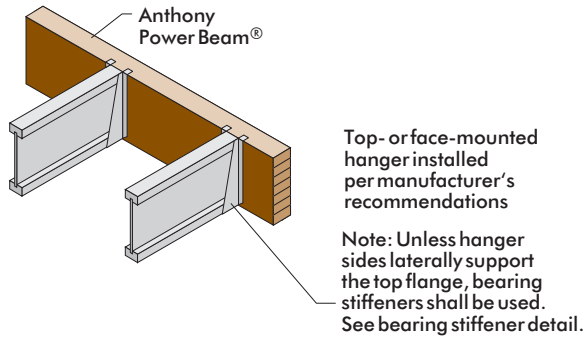

1k

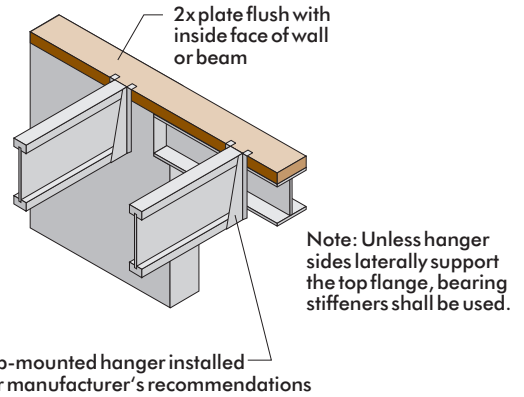

1m

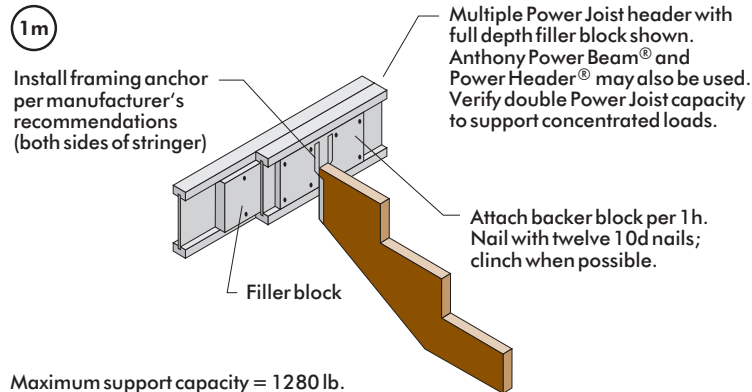

1n

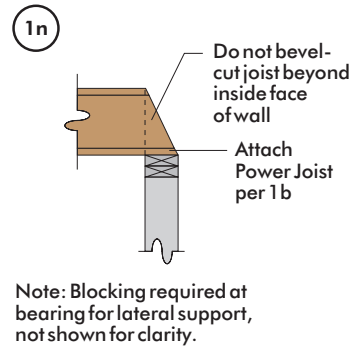

Typical Floor Framing and Construction Details

Installation Notes:

1. Installation of ADI Power Joist shall be in accordance with Figure 1.
2. Except for cutting joist to length, Power Joist flanges should never be cut, drilled, or notched.
3. Concentrated loads should only be applied to the top surface of the top flange. At no time should concentrated loads be suspended from the bottom flange with the exception of light loads such as ceiling fans, light fixtures, etc.
4. Power Joists must be protected from the weather prior to installation.
5. Power Joists must not be used in applications where they will be permanently exposed to weather, or will reach a moisture content greater than 16% such as in swimming pool or hot tub areas. They must not be installed where they will remain in direct contact with concrete or masonry.
6. End bearing length must be at least 1-3/4". For multiple span joists, intermediate bearing length must be at least 3-1/2".
7. Ends of floor joists shall be restrained to prevent rollover. Use Certified Rim Board or Power Joist blocking panels.
8. Power Joists installed beneath bearing walls perpendicular to the joists require full depth blocking panels, Certified Rim Board, or squash blocks (cripple blocks) to transfer gravity loads from above the floor system to the wall or foundation below (see note 1g page 9).
9. For Power Joists installed as rim board directly beneath bearing walls parallel to the joists, the maximum allowable vertical load using a single Power Joist is 2,000 plf, and 4,000 plf if double Power Joists are used. Full bearing is required under Power Joist used as rim board.
10. Continuous lateral support of the Power Joist's compression flange is required to prevent rotation and buckling. In simple span uses, lateral support of the top flange is normally supplied by the floor sheathing. In multiple span or cantilever applications, bracing of the Power Joist's bottom flange is also required at interior supports of multiple-span joists, and at the end support next to the cantilever extension. The ends of all cantilever extensions must be laterally braced as shown in Figure 2, 3 or 4a.
11. Nails installed perpendicular to the wide face of the flange shall be spaced in accordance with the applicable building code requirements or approved building plans but should not be closer than 2" o.c. per row.
12. Figures 1–4 on the following pages show only Power Joist-specific fastener requirements. For other fastener requirements, see the applicable building code.

Cantilever Details for Balconies (No Wall Load)

Balconies may be constructed using either continuous Power Joists (Figure 2) or by adding lumber extensions (Figure 3) to the Power Joist. Continuous Power Joist cantilevers are limited to one-fourth the adjacent span when supporting uniform loads only. For applications supporting concentrated loads at the end of the cantilever, such as a wall, see Figures 4a and 4b.

Unless otherwise engineered, cantilevers are limited to a maximum of 4' when supporting uniform loads only. Blocking is required at the cantilever support as shown.

Uniform floor load shall not exceed 40 psf live load and 10 psf dead load. The balcony load shall not exceed 60 psf live load and 10 psf dead load. If more than 70 psf total load design analysis must be performed.

Figure 2

I-Joist Cantilever Detail for Balconies

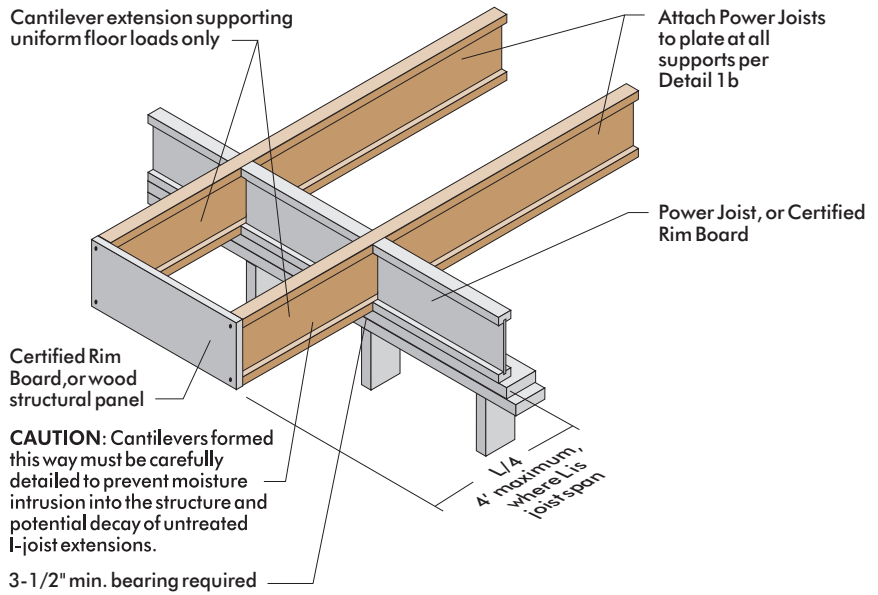
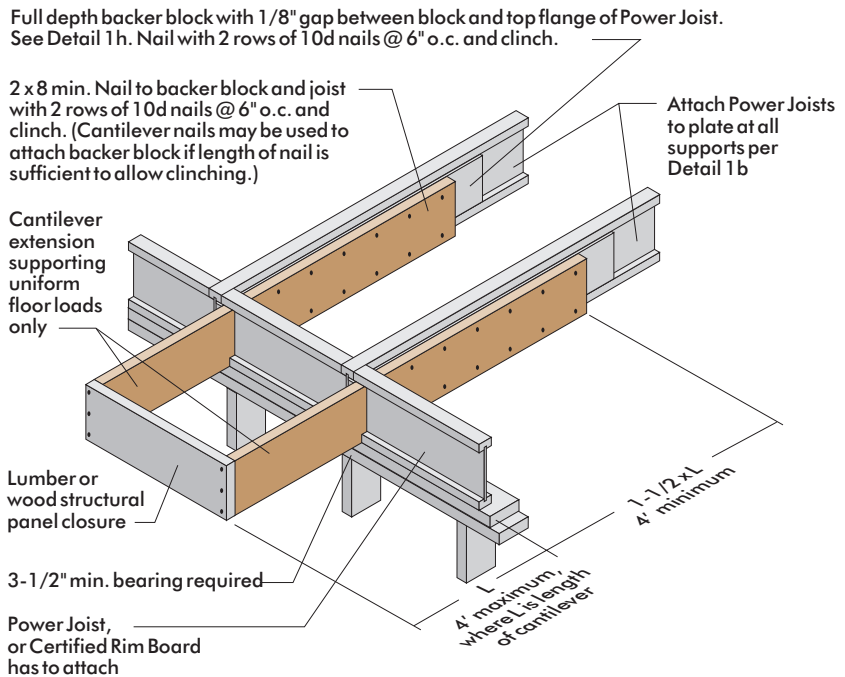

Figure 3

Lumber Cantilever Detail for Balconies



Cantilever Details for Vertical Building Offset (Concentrated Wall Load)

Power Joist may also be used in cantilever applications supporting a concentrated load applied to the end of the cantilever, such as with a vertical building offset. For cantilever-end concentrated load applications that require reinforcing based on Table 5, the cantilever is limited to 2' maximum. In addition, blocking is required along the cantilever support and for 4' on each side of the cantilever area. Depending on the magnitude of the roof load and joist layout (see Table 5), three methods of reinforcing are allowed in load bearing cantilever applications: reinforcing sheathing applied to one side of the Power Joist (Method 1), reinforcing sheathing applied to both sides of the joist or double Power Joists (Method 2).

Figure 4a

Cantilever Detail for Vertical Building Offset

Method 1

Sheathing reinforcement one side

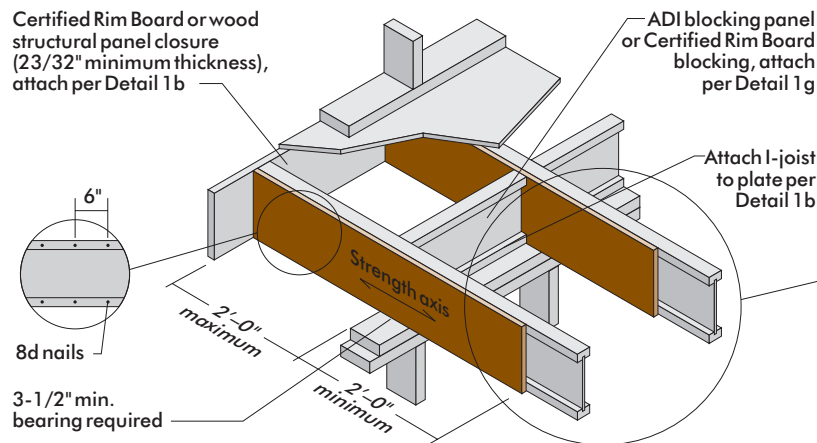

Method 2

Sheathing reinforcement two sides

Use same installation as Method 1 but reinforce both sides of Power Joist with sheathing

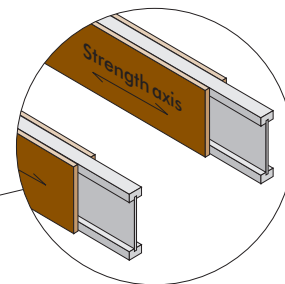

Use nailing pattern shown for Method 1 with opposite face nailing offset by 3"

Note: APA RATED SHEATHING 48/24 (minimum thickness 23/32") required on sides of joist. Depth shall match the full height of the joist. Nail with 8d nails at 6" o.c., top and bottom flange. Install with face grain horizontal. Attach Power Joist to plate at all supports per Detail 1b

Alternate Method 2

Double I-Joist

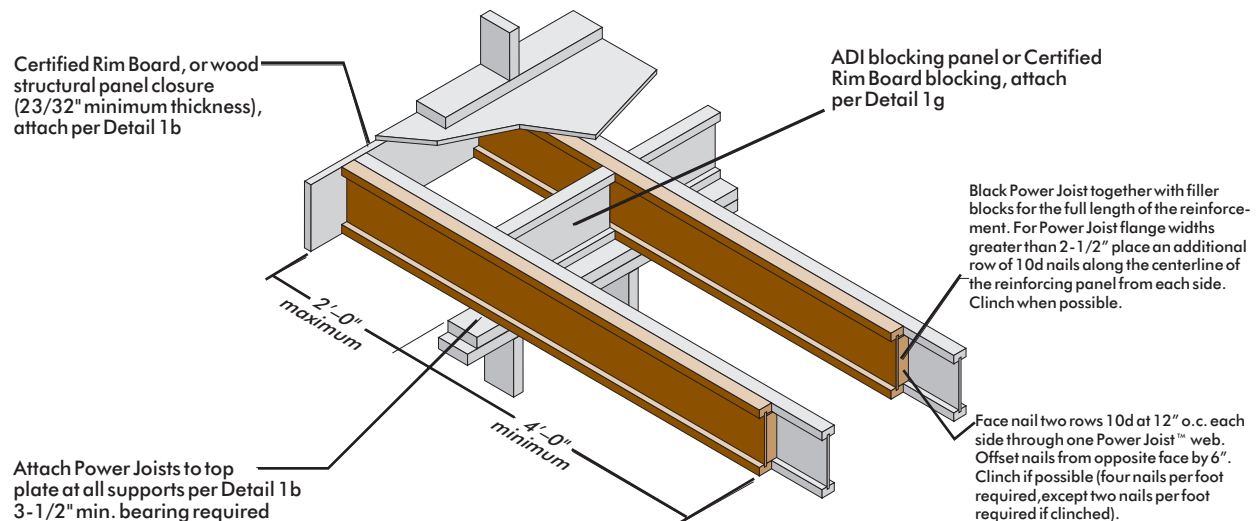

Cantilever Reinforcement Methods

Figure 4b

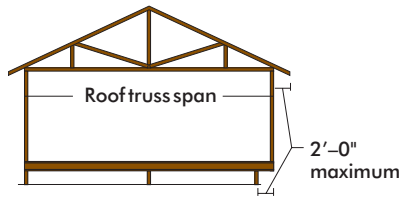

See Table below for ADI reinforcement requirements at cantilever.

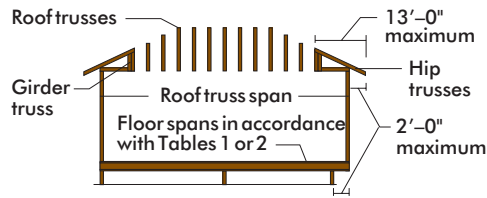

For hip roofs with the hip trusses running parallel to the cantilevered floor joists, the Power Joist reinforcement requirements for a span of 26' shall be permitted to be used.

Table 5

ADI Power Joist Cantilever Reinforcement Methods Allowed

Joist Depth (in.)	Roof Truss Span (ft.)	ROOF LOADINGS											
		TL = 35 psf LL not to exceed 20 psf				TL = 45 psf LL not to exceed 30 psf				TL = 55 psf LL not to exceed 40 psf			
		Joist Spacing (in.)				Joist Spacing (in.)				Joist Spacing (in.)			
		12	16	19.2	24	12	16	19.2	24	12	16	19.2	24
9-1/2	26	N	N	N	1,2	N	N	1,2	2	N	1,2	2	X
	28	N	N	1,2	1,2	N	N	1,2	2	N	1,2	2	X
	30	N	N	1,2	1,2	N	1,2	1,2	2	N	1,2	2	X
	32	N	N	1,2	2	N	1,2	1,2	X	N	1,2	2	X
	34	N	N	1,2	2	N	1,2	2	X	N	2	X	X
	36	N	N	1,2	2	N	1,2	2	X	N	2	X	X
11-7/8	26	N	N	N	1,2	N	N	1,2	1,2	N	1,2	1,2	2
	28	N	N	1,2	1,2	N	1,2	1,2	1,2	N	1,2	1,2	2
	30	N	N	1,2	1,2	N	1,2	1,2	2	N	1,2	1,2	2
	32	N	N	1,2	1,2	N	1,2	1,2	2	N	1,2	1,2	2
	34	N	N	1,2	1,2	N	1,2	1,2	2	N	1,2	2	2
	36	N	N	1,2	1,2	N	1,2	1,2	2	N	1,2	2	2
14	26	N	N	N	1,2	N	N	N	1,2	N	N	1,2	1,2
	28	N	N	N	1,2	N	N	1,2	1,2	N	N	1,2	2
	30	N	N	N	1,2	N	N	1,2	1,2	N	1,2	1,2	2
	32	N	N	N	1,2	N	N	1,2	1,2	N	1,2	1,2	2
	34	N	N	N	1,2	N	N	1,2	2	N	1,2	1,2	2
	36	N	N	1,2	1,2	N	1,2	1,2	2	N	1,2	1,2	2
16	26	N	N	N	1,2	N	N	1,2	1,2	N	N	1,2	1,2
	28	N	N	N	1,2	N	N	1,2	1,2	N	1,2	1,2	2
	30	N	N	N	1,2	N	N	1,2	1,2	N	1,2	1,2	2
	32	N	N	N	1,2	N	N	1,2	1,2	N	1,2	1,2	2
	34	N	N	1,2	1,2	N	N	1,2	2	N	1,2	1,2	2
	36	N	N	1,2	1,2	N	1,2	1,2	2	N	1,2	1,2	2
16	26	N	N	N	1,2	N	N	1,2	1,2	N	N	1,2	1,2
	28	N	N	N	1,2	N	N	1,2	1,2	N	1,2	1,2	2
	30	N	N	N	1,2	N	N	1,2	1,2	N	1,2	1,2	2
	32	N	N	N	1,2	N	N	1,2	1,2	N	1,2	1,2	2
	34	N	N	1,2	1,2	N	N	1,2	2	N	1,2	1,2	2
	36	N	N	1,2	1,2	N	1,2	1,2	2	N	1,2	1,2	2
16	26	N	N	N	1,2	N	N	1,2	1,2	N	N	1,2	1,2
	28	N	N	N	1,2	N	N	1,2	1,2	N	1,2	1,2	2
	30	N	N	N	1,2	N	N	1,2	1,2	N	1,2	1,2	2
	32	N	N	N	1,2	N	N	1,2	1,2	N	1,2	1,2	2
	34	N	N	1,2	1,2	N	N	1,2	2	N	1,2	1,2	2
	36	N	N	1,2	1,2	N	1,2	1,2	2	N	1,2	1,2	2
16	26	N	N	N	1,2	N	N	1,2	1,2	N	N	1,2	1,2
	28	N	N	N	1,2	N	N	1,2	1,2	N	1,2	1,2	2
	30	N	N	N	1,2	N	N	1,2	1,2	N	1,2	1,2	2
	32	N	N	N	1,2	N	N	1,2	1,2	N	1,2	1,2	2
	34	N	N	1,2	1,2	N	N	1,2	2	N	1,2	1,2	2
	36	N	N	1,2	1,2	N	1,2	1,2	2	N	1,2	1,2	2
16	26	N	N	N	1,2	N	N	1,2	1,2	N	N	1,2	1,2
	28	N	N	N	1,2	N	N	1,2	1,2	N	1,2	1,2	2
	30	N	N	N	1,2	N	N	1,2	1,2	N	1,2	1,2	2
	32	N	N	N	1,2	N	N	1,2	1,2	N	1,2	1,2	2
	34	N	N	1,2	1,2	N	N	1,2	2	N	1,2	1,2	2
	36	N	N	1,2	1,2	N	1,2	1,2	2	N	1,2	1,2	2
16	26	N	N	N	1,2	N	N	1,2	1,2	N	N	1,2	1,2
	28	N	N	N	1,2	N	N	1,2	1,2	N	1,2	1,2	2
	30	N	N	N	1,2	N	N	1,2	1,2	N	1,2	1,2	2
	32	N	N	N	1,2	N	N	1,2	1,2	N	1,2	1,2	2
	34	N	N	1,2	1,2	N	N	1,2	2	N	1,2	1,2	2
	36	N	N	1,2	1,2	N	1,2	1,2	2	N	1,2	1,2	2
16	26	N	N	N	1,2	N	N	1,2	1,2	N	N	1,2	1,2
	28	N	N	N	1,2	N	N	1,2	1,2	N	1,2	1,2	2
	30	N	N	N	1,2	N	N	1,2	1,2	N	1,2	1,2	2
	32	N	N	N	1,2	N	N	1,2	1,2	N	1,2	1,2	2
	34	N	N	1,2	1,2	N	N	1,2	2	N	1,2	1,2	2
	36	N	N	1,2	1,2	N	1,2	1,2	2	N	1,2	1,2	2
16	26	N	N	N	1,2	N	N	1,2	1,2	N	N	1,2	1,2
	28	N	N	N	1,2	N	N	1,2	1,2	N	1,2	1,2	2
	30	N	N	N	1,2	N	N	1,2	1,2	N	1,2	1,2	2
	32	N	N	N	1,2	N	N	1,2	1,2	N	1,2	1,2	2
	34	N	N	1,2	1,2	N	N	1,2	2	N	1,2	1,2	2
	36	N	N	1,2	1,2	N	1,2	1,2	2	N	1,2	1,2	2
16	26	N	N	N	1,2	N	N	1,2	1,2	N	N	1,2	1,2
	28	N	N	N	1,2	N	N	1,2	1,2	N	1,2	1,2	2
	30	N	N	N	1,2	N	N	1,2	1,2	N	1,2	1,2	2
	32	N	N	N	1,2	N	N	1,2	1,2	N	1,2	1,2	2
	34	N	N	1,2	1,2	N	N	1,2	2	N	1,2	1,2	2
	36	N	N	1,2	1,2	N	1,2	1,2	2	N	1,2	1,2	2
16	26	N	N	N	1,2	N	N	1,2	1,2	N	N	1,2	1,2
	28	N	N	N	1,2	N	N	1,2	1,2	N	1,2	1,2	2
	30	N	N	N	1,2	N	N	1,2	1,2	N	1,2	1,2	2
	32	N	N	N	1,2	N	N	1,2	1,2	N	1,2	1,2	2
	34	N	N	1,2	1,2	N	N	1,2	2	N	1,2	1,2	2
	36	N	N	1,2	1,2	N	1,2	1,2	2	N	1,2	1,2	2
16	26	N	N	N	1,2	N	N	1,2	1,2	N	N	1,2	1,2
	28	N	N	N	1,2	N	N	1,2	1,2	N	1,2	1,2	2
	30	N	N	N	1,2	N	N	1,2	1,2	N	1,2	1,2	2
	32	N	N	N	1,2	N	N	1,2	1,2	N	1,2	1,2	2
	34	N	N	1,2	1,2	N	N	1,2	2	N	1,2	1,2	2
	36	N	N	1,2	1,2	N	1,2	1,2	2	N	1,2	1,2	2
16	26	N	N	N	1,2	N	N	1,2	1,2	N	N	1,2	1,2
	28	N	N	N	1,2	N	N	1,2	1,2	N	1,2	1,2	2
	30	N	N	N	1,2	N	N	1,2	1,2	N	1,2	1,2	2
	32	N	N	N	1,2	N	N	1,2	1,2	N	1,2	1,2	2
	34	N	N	1,2	1,2	N	N	1,2	2	N	1,2	1,2	2
	36	N	N	1,2	1,2	N	1,2	1,2	2	N	1,2	1,2	2
16	26	N	N	N	1,2	N	N	1,2	1,2	N	N	1,2	1,2
	28	N	N	N	1,2	N	N	1,2	1,2	N	1,2	1,2	2
	30	N	N	N	1,2	N	N	1,2	1,2	N	1,2	1,2	2
	32	N	N	N	1,2	N	N	1,2	1,2	N	1,2	1,2	2
	34	N	N	1,2	1,2	N	N	1,2	2	N	1,2	1,2	2
	36	N	N	1,2	1,2	N	1,2	1,2	2	N	1,2	1,2	2
16	26	N	N	N	1,2	N	N	1,2	1,2	N	N	1,2	1,2
	28	N	N	N	1,2	N	N	1,2	1,2	N	1,2	1,2	2
	30	N	N	N	1,2	N	N	1,2	1,2	N	1,2	1,2	2
	32	N	N	N	1,2	N	N	1,2	1,2	N	1,2	1,2	2
	34	N	N	1,2	1,2	N	N	1,2	2	N	1,2	1,2	2
	36	N	N	1,2	1,2	N	1,2	1,2	2	N	1,2	1,2	2
16	26	N	N	N	1,2	N	N	1,2	1,2	N	N	1,2	1,2
	28	N	N	N	1,2	N	N	1,2	1,2	N	1,2	1,2	2
	30	N	N	N	1,2	N	N	1,2	1,2	N	1,2	1,2	2
	32	N	N	N	1,2	N	N	1,2	1,2	N	1,2	1,2	2
	34	N	N	1,2	1,2	N	N	1,2	2	N	1,2	1,2	2
	36	N	N	1,2	1,2	N	1,2	1,2	2	N	1,2	1,2	2
16	26	N	N	N	1,2	N	N	1,2	1,2	N	N	1,2	1,2
	28	N	N	N	1,2	N							

Web Hole Rules and Specifications

One of the benefits of using Power Joist in residential floor construction is that holes may be cut in the joist webs to accommodate electrical wiring, plumbing lines and other mechanical systems, therefore minimizing the depth of the floor system.

Rules for cutting holes in PRI Joists

1. The distance between the inside edge of the support and the center line of any hole shall be in compliance with the requirements of page 16.
2. I-Joist top and bottom flanges must NEVER be cut, notched, or otherwise modified.
3. Whenever possible field-cut holes should be centered on the middle of the web.
4. The maximum size hole that can be cut into a I-Joist web shall equal the clear distance between the flanges of the I-joist minus 1/4-inch. A minimum of 1/8 inch should always be maintained between the top or bottom of the hole and the adjacent I-Joist flange.
5. The sides of square holes or longest sides of rectangular holes should not exceed three fourths of the diameter of the maximum round hole permitted at that location.
6. Where more than one hole is necessary, the distance between adjacent hole edges shall exceed twice the diameter of the largest round hole or twice the size of the largest square hole (*or twice the length of the longest side of the longest rectangular hole*) and each hole must be sized and located in compliance with the requirements of Table 6.
7. A knockout is **not** considered a hole, may be utilized anywhere it occurs and may be ignored for purposes of calculating minimum distances between holes.
8. One and one-half inch holes shall be permitted anywhere in a cantilevered section of a PRI Joist. Holes of greater size may be permitted subject to verification.
9. A 1-1/2" hole can be placed anywhere in the web provided that it meets the requirements of 6 above.
10. For joists with more than one span, use the longest span to determine hole location in either span.
11. All holes shall be cut in a workman-like manner in accordance with the restrictions listed above and as illustrated in Figure 5.
12. Limit 3 maximum size holes per span.
13. A group of round holes at approximately the same location shall be permitted if they meet the requirements for a single round hole circumscribed around them.

Figure 5

ADI Power Joist™ Typical Holes

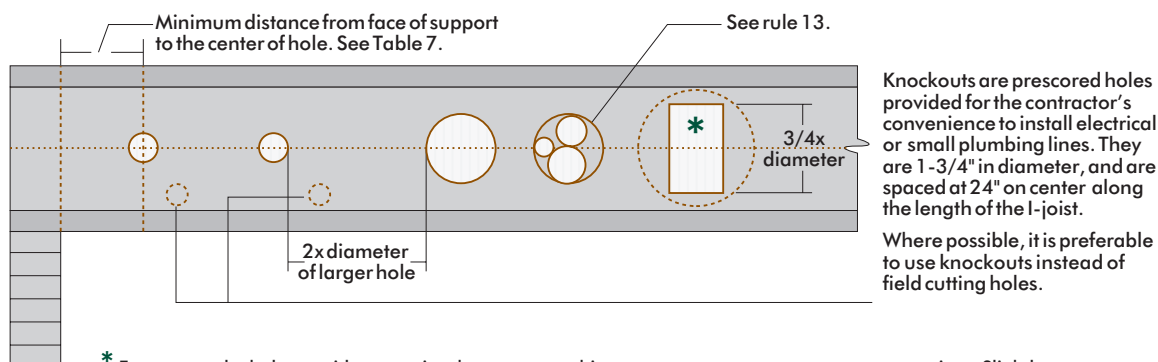

* For rectangular holes, avoid over cutting the corners, as this can cause unnecessary stress concentrations. Slightly rounding the corners is recommended. Starting the rectangular hole by drilling a 1" diameter hole in each of the 4 corners and then making the cuts between the holes is another good method to minimize damage to I-joist.

Web Hole Specifications

Table 6 Allowable Round Hole Web Opening Size and Locations 1, 2, 3, 4																	
(Simple or Multiple Spans for Dead Loads up to 10 psf and Live Loads up to 40 psf)																	
Joist Depth (inches)	Power Joist	Span Adjustment Factor (SAF)	Round Hole Diameter (in.)														
			2	3	4	5	6	6-1/4	7	8	8-5/8	9	10	10-3/4	11	12	12-3/4
9-1/2"	ADI-40	14.7	0'-6"	2'-0"	3'-0"	4'-6"	6'-0"	6'-6"	N/A	N/A	N/A	N/A	N/A	N/A	N/A	N/A	N/A
	ADI-60	16.6	2'-0"	3'-0"	4'-6"	6'-0"	7'-6"	8'-0"	N/A	N/A	N/A	N/A	N/A	N/A	N/A	N/A	N/A
11-7/8"	ADI-40	16.7	0'-6"	0'-6"	1'-6"	2'-6"	4'-0"	4'-6"	5'-6"	7'-0"	8'-0"	N/A	N/A	N/A	N/A	N/A	N/A
	ADI-60	19.7	1'-0"	2'-0"	3'-6"	4'-6"	6'-0"	6'-6"	7'-6"	9'-0"	10'-0"	N/A	N/A	N/A	N/A	N/A	N/A
	ADI-80	21.7	2'-0"	3'-6"	4'-6"	6'-0"	7'-6"	8'-0"	9'-0"	10'-6"	11'-6"	N/A	N/A	N/A	N/A	N/A	N/A
14"	ADI-40	18.3	0'-6"	0'-6"	0'-6"	1'-0"	2'-0"	2'-6"	3'-6"	5'-0"	5'-6"	6'-0"	8'-0"	9'-6"	N/A	N/A	N/A
	ADI-60	19.9	0'-6"	0'-6"	0'-6"	2'-0"	3'-6"	3'-6"	5'-0"	6'-6"	8'-0"	8'-6"	10'-6"	12'-0"	N/A	N/A	N/A
	ADI-80	23.11	0'-6"	2'-0"	3'-0"	4'-6"	6'-0"	6'-6"	7'-6"	9'-0"	10'-0"	10'-6"	12'-6"	14'-0"	N/A	N/A	N/A
16"	ADI-40	19.8	0'-6"	0'-6"	0'-6"	0'-6"	0'-6"	0'-6"	1'-6"	3'-0"	4'-0"	4'-6"	5'-6"	7'-0"	7'-0"	9'-0"	11'-0"
	ADI-60	19.9	0'-6"	0'-6"	0'-6"	0'-6"	0'-6"	1'-0"	2'-0"	3'-6"	4'-6"	5'-6"	7'-6"	9'-0"	9'-6"	12'-0"	14'-0"
	ADI-80	23.11	0'-6"	0'-6"	0'-6"	2'-0"	3'-6"	4'-0"	5'-0"	6'-6"	8'-0"	8'-6"	10'-6"	12'-0"	12'-6"	14'-6"	16'-0"

SI: 1 inch = 25.4 mm; 1 foot = 304.8 mm

N/A = Not Allowed

- The above tables limited to Power Joist spacing of 24-inches on center or less.
- Distances are based on uniformly loaded I-joists.
- Hole location distance is measured from inside face of supports to center of hole.
- For continuous I-joists with more than one span, use the longest span to determine hole locations.
- If the I-joist are placed less than the full allowable span, the maximum distance from the centerline of the holes to the inside face of any support (D) as given below is permitted to be reduced as follows:

$$D_{\text{reduced}} = \frac{L_{\text{actual}}}{\text{SAF}} \times D$$

Where:

- D_{reduced} = Distance from the inside face of any support to center of hole, reduced for less-than-maximum span applications (feet).
- L_{actual} = The actual measured span distance between the inside faces of supports (feet).
- SAF = Span Adjustment Factor.
- D = The minimum distance from the inside face of any support to center of hole from Table 7 above.

Note: If $\frac{L_{\text{actual}}}{\text{SAF}}$ is greater than 1, use 1 in the above calculation.

- Manufacturer's pre-scored 1-1/2-inch knockouts are not considered a hole and can be ignored for purposes of calculating minimum distances between holes.

When calculating hole locations by this optional method, the following minimum distances between the center of the hole and the inside face of the support apply:

Hole Diameter	2	3	4	5	6	6-1/4	7	8	8-5/8	9	10	10-3/4	11	12	12-3/4
in inches															
(mm)	(51)	(76)	(101)	(127)	(152)	(159)	(178)	(202)	(219)	(228)	(254)	(273)	(279)	(305)	(324)
Minimum Distance															
in feet	0.5	0.5	1	1	1	1.5	1.5	1.5	1.5	1.5	1.5	1.5	1.5	1.5	2
(mm)	(150)	(150)	(300)	(300)	(300)	(450)	(450)	(450)	(450)	(450)	(450)	(450)	(450)	(450)	(600)

Figure 6

Do Not Cut or Drill

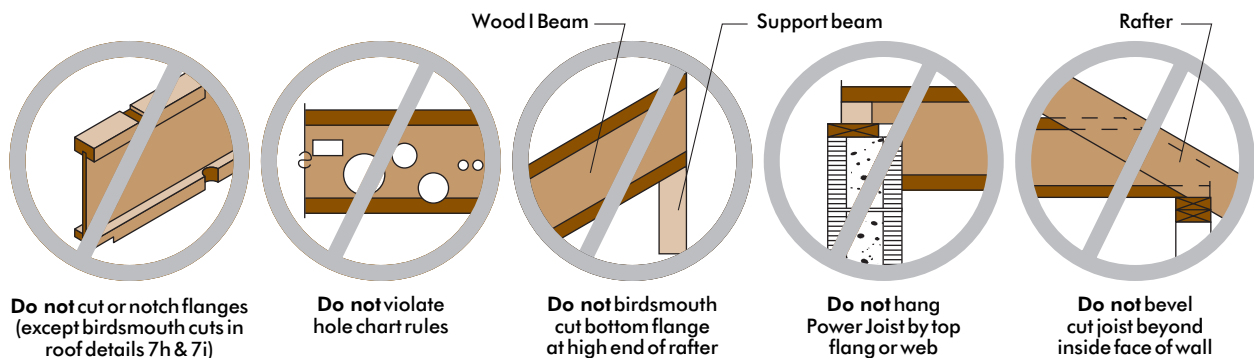

Rim Board Hole Specifications

The maximum allowable hole size for an APA Rim Board shall be 2/3 of the Rim Board depth as shown below. The length of the Rim Board segment containing a hole shall be at least 8 times the hole size.

Table 7

Rim Board Hole Sizes and Maximum Length

Rim Board Depth (in.)	Maximum Allowable Hole Size (a)(b) (in.)	Minimum Length of Rim Board Segment (c) for the Maximum Allowable Hole Size (in.)
9-1/2	9-1/2	9-1/2
9-1/2	9-1/2	9-1/2
9-1/2	9-1/2	9-1/2
9-1/2	9-1/2	9-1/2

(a) These hole provisions do not apply to Rim Board installed over openings, such as doors or windows.
 (b) The diameter of a round hole or the longer dimension of a rectangular hole.
 (c) The length of Rim Board segment per wall line. For multiple holes, the minimum length of Rim Board shall be 8 times the sum of all hole sizes.

Application Notes

1. Do not cut holes in Rim Board installed over openings, such as doors or windows, where the Rim Board is not fully supported, except that holes of 1-1/2 inches or less in size are permitted provided they are positioned at the mid-depth and in the middle 1/3 of the span (see Note 5 for minimum hole spacing).

Figure 6A

RIM BOARD OVER AN OPENING

Do not cut holes in Rim Board over opening except for holes of 1-1/2" or less in size (see Note 1).

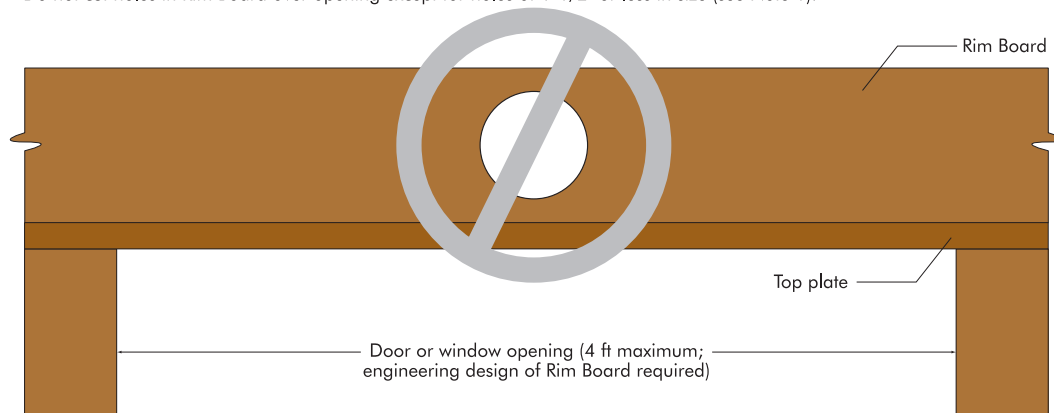

2. Field-cut holes should be vertically centered in the Rim Board and at least one hole diameter or 6 inches, whichever is less, clear distance away from the end of the wall line. Holes should never be placed such that they interfere with the attachment of the Rim Board to the ends of the floor joist, or any other code-required nailing.

3. While round holes are preferred, rectangular holes may be used providing the corners are not over-cut. Slightly rounding corners or pre-drilled corners with a 1-inch-diameter bit is recommended.

4. When concentrated loads are present on the Rim Board (load not supported by any other vertical-load-carrying members such as squash blocks), holes should not be placed in the Rim Board within a distance equal to the depth of the Rim Board from the area of loading.

Figure 6B

Rim Board Near Concentrated Vertical Load

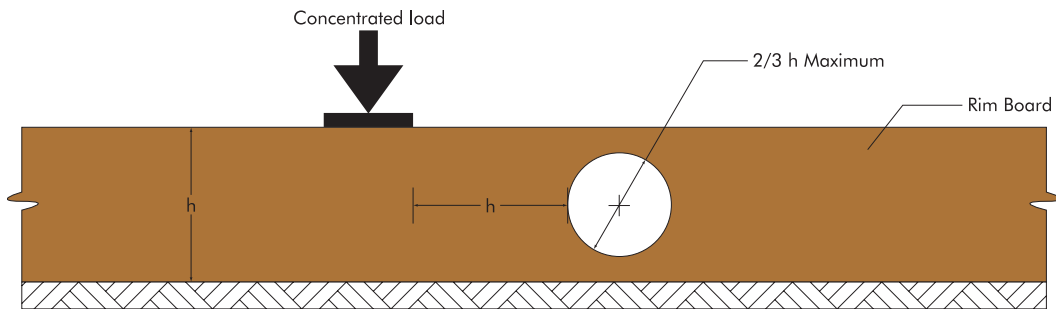

5. For multiple holes, the clear spacing between holes shall be at least two times the diameter of the larger hole, or twice the length of the longest side of the longest rectangular hole. This minimum hole spacing does not apply to holes of 1-1/2 inches or less in diameter, which can be placed anywhere in the Rim Board (see Note 1 for holes over opening) except that the clear distance to the adjacent hole shall be 3 inches minimum.

Figure 6C

Multiple Holes for Rim Board

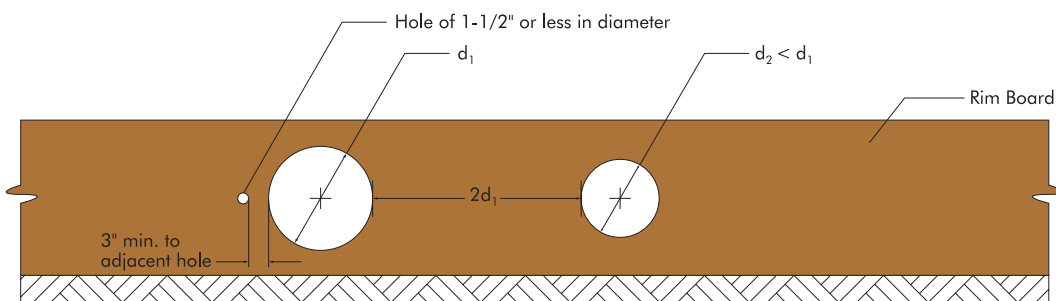

6. All holes shall be cut in a workman-like manner in accordance with the limitations listed above.

Figure 7

Roof Framing and Construction Details

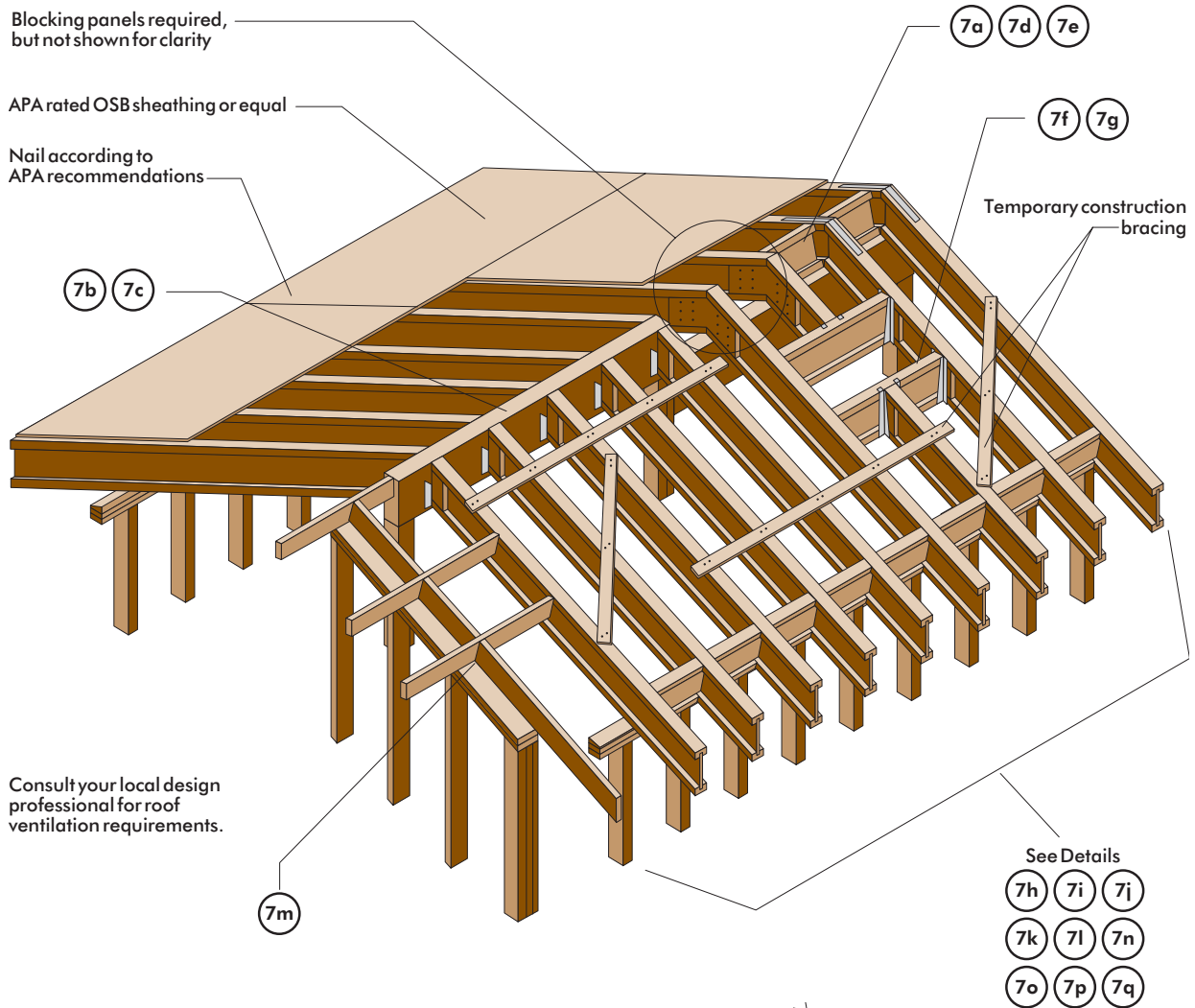

Slope Spans for Rafters

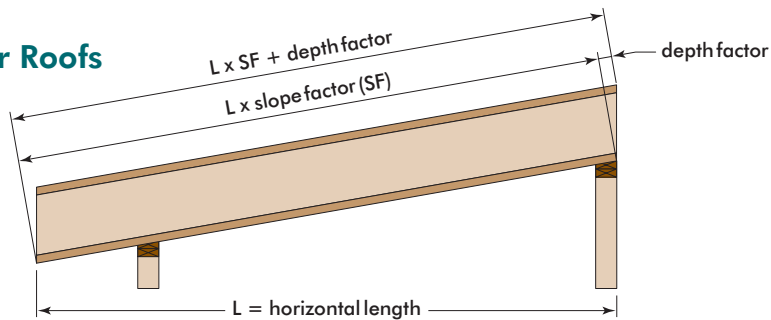

Slope Factor and Depth Factor Table

Slope	2½:12	3:12	3½:12	4:12	4½:12	5:12	6:12	7:12	8:12	9:12	10:12	11:12	12:12	
Slope Factor	1.022	1.031	1.042	1.054	1.068	1.083	1.118	1.158	1.202	1.25	1.302	1.357	1.414	
Depth Factor	9-1/2"	2"	2-3/8"	2-7/8"	3-1/4"	3-5/8"	4"	4-3/4"	5-5/8"	6-3/8"	7-1/8"	8"	8-3/4"	9-1/2"
	11-7/8"	2-1/2"	3"	3-1/2"	4"	4-1/2"	5"	6"	7"	8"	9"	10"	11"	11-7/8"
	14"	3"	3-1/2"	4-1/8"	4-3/4"	5-1/4"	5-7/8"	7"	8-1/4"	9-3/8"	10-1/2"	11-3/4"	12-7/8"	14"
	16"	3-3/8"	4"	4-3/4"	5-3/8"	6"	6-3/4"	8"	9-3/8"	10-3/4"	11-3/4"	13-3/8"	14-3/4"	16"

Figure 7 Continued

All nails shown in the details 7a through 7i are assumed to be common nails unless otherwise noted. 10d box nails may be substituted for 8d common shown in details. Individual components not shown to scale for clarity. 12:12 Maximum roof slope.

7a Upper End, Bearing on Wall

8d nails at 6" o.c. – minimum 3–8d nails per blocking panel. (When used for lateral shear transfer, match nail type and sheathing edge nailing ("boundary nailing") for engineered diaphragm applications.) Use minimum 8d nails.

Blocking panel, x-briding, or 23/32" APA Rated Sheathing 48/24 as continuous closure (Validate use of x-briding with local building code.)

Minimum attachment:
For slope 1/4:12, one 10d box nail, face nail at each side of bearing.
For slope > 1/4:12 design joist attachment to beveled plate to transfer lateral thrust.

Bearing stiffener required when end reaction exceeds 1550 lb.

Beveled plate for slopes greater than 1/4:12. Code-recognized connectors may be substituted. For slopes greater than 4:12 connectors are required to resist lateral thrust.

Note: Additional connection may be required for wind uplift.

Attach beveled plate to framing with 1 - 16d at 16" o.c.

7b Peak Connection

For roof slopes between 1/4:12 and 12:12, provide a strap tie nailed in accordance with a min. 3" nail spacing wrapped around ridge beam

Anthony Power Beam®

Beveled bearing stiffener required each side

Adjustable Slope Hanger with a minimum unadjusted uplift capacity of 300 lb.

Note: Additional connection may be required for wind uplift.

7c Power Joist to Power Beam® Connection

Adjustable Slope Hanger with a minimum unadjusted uplift capacity of 300 lb.

For roof slopes between 1/4:12 and 12:12, provide a strap nailed with a min. 3" nail spacing on each side of roof slope

Beveled bearing stiffener required each side

Power Beam®

Note: Additional connection may be required for wind uplift

7d Power Joist Connection with Wood Structural Panel Gussets

23/32" x 2'-0" wood structural panel (front and back sides) with 12-8d nails into each joist with nails clinched. When roof live load exceeds 40 psf, horizontal orientation of gusset strong axis is required. Gap 1/8" at top

Blocking panel or x-briding. Attach per Fig. 7a

24"

Support beam or wall

Attach beveled plate to framing with 1 - 16d at 16" o.c.

Note: Additional connection may be required for wind uplift.

7e Rafter Connection with Overlapping I-Joists

8-8d nails each side

Blocking panel, attach per Fig. 7a

Filler block

Attach each Power Joist to beveled top plate per Fig. 7a

Filler block 8-8d nails 4 each side

Support beam or wall

Attach bevel plate to beam or wall per Fig. 7d

7f Roof Opening Top Mounted Hangers

Top mounted hanger per manufacturer's recommendations

Bearing stiffeners required when hanger does NOT support Power Joist top flange.

Application limited to 4:12 slope

Backer block. If top-mounted hanger is fully supported by top flange, backer block only required on hanger side. If face nailing is required, then second backer block (filler block if multiple I-joist) is required. Nail with 10-10d nails for flanges up to 1-3/4" wide. Use 12-10d nails for flanges wider than 1-3/4".

Filler blocking

Figure 7 Continued

7g Roof Opening, Face-Mounted Hangers

Backer block on both sides of web (or backer block and filler block, if multiple Power Joists), nail with 12-10d nails clinch when possible.

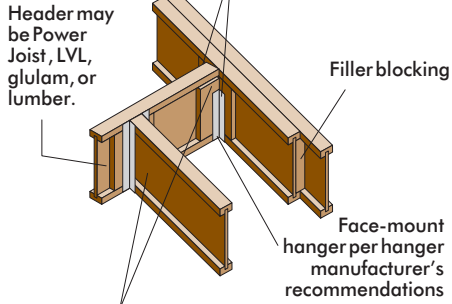

Bearing stiffeners required when hanger does not support Power Joist top flange

7h Birdsmouth Cut & Bevel Cut Bearing Stiffener

Permitted on low end of I-joist only

Bearing stiffeners required each side of Power Joist. Bevel cut bearing stiffener to match roof slope.

4-8d nails (two each side) clinched when possible.

Birdsmouth cut shall bear fully and not overhang the inside face of plate

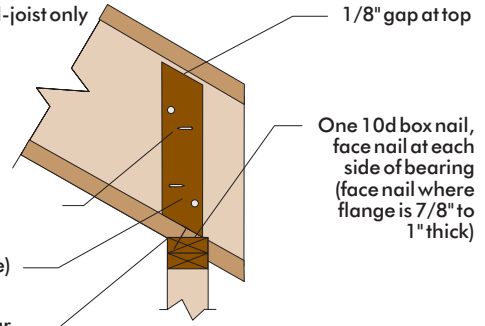

Note: Additional connection may be required for wind uplift.

7i Birdsmouth Cut with Overhang (Permitted on low end of Power Joist only)

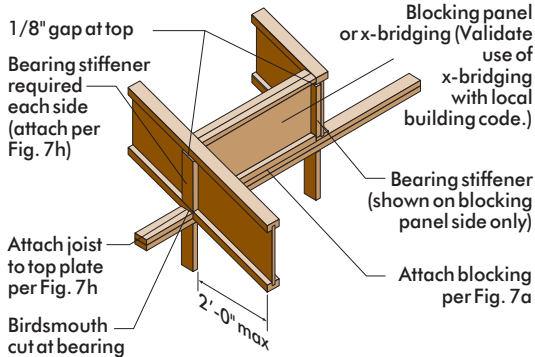

Note: Additional connection may be required for wind uplift.
Note: Outside corner of blocking panel may be trimmed if it interferes with roof sheathing. In such cases, position blocking panel on top plate to minimize trimming and still allow required nailing into top plate.

7j I-Joist Overhang for Fascia Support with Birdsmouth Cut

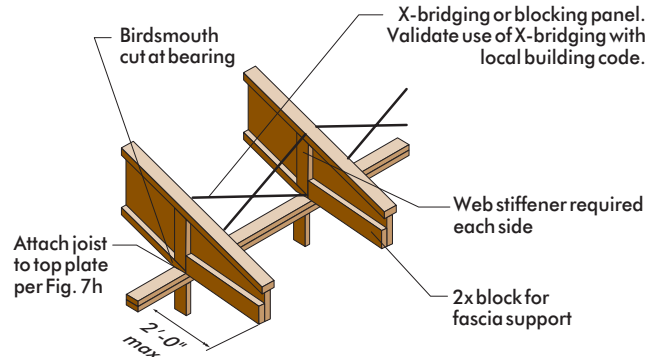

7k Blocking Panel at Beveled Plate

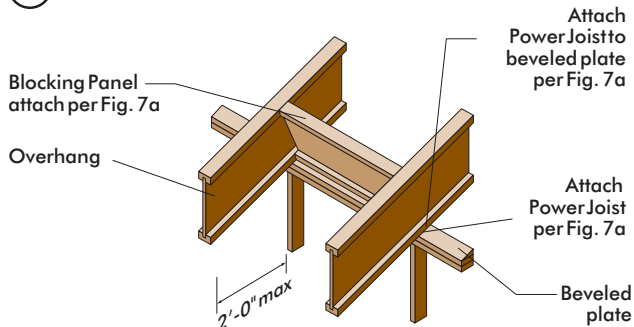

Note: Additional connection may be required for wind uplift.

7l Power Joist with Bevel-Cut End

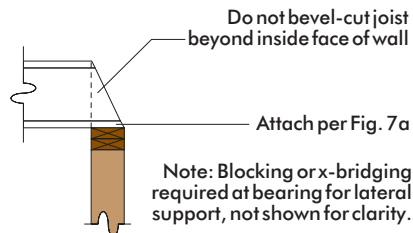

Note: Additional connection may be required for wind uplift.

Figure 7 Continued

All nails shown in the details 7m through 7q are assumed to be common nails unless otherwise noted. 10d box nails may be substituted for 8d common shown in details. Individual components not shown for clarity.

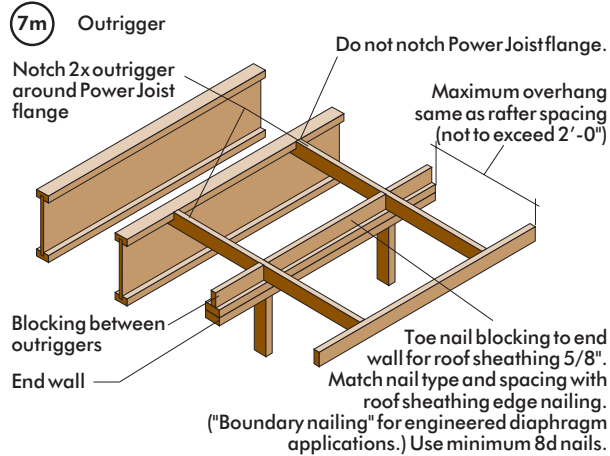

Note: Additional connection may be required for wind uplift.

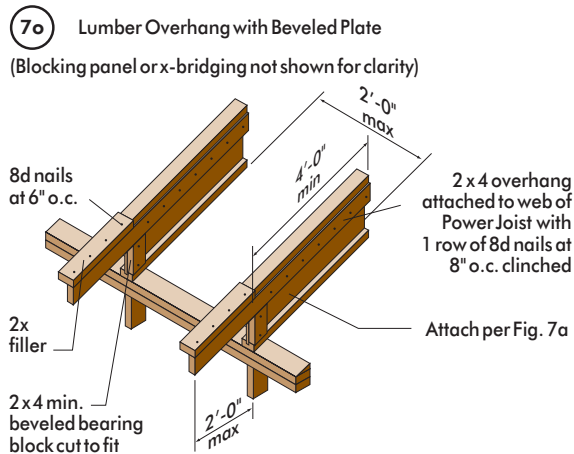
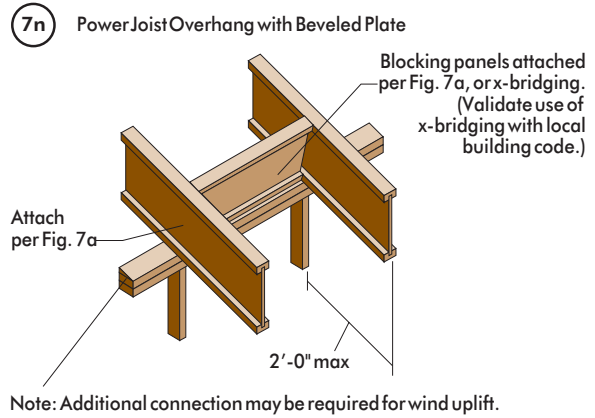

Note: Additional connection may be required for wind uplift.

Note: Lumber overhang shall be 2 x 4 Spruce-Pine-Fir #2 or better, or stronger species.

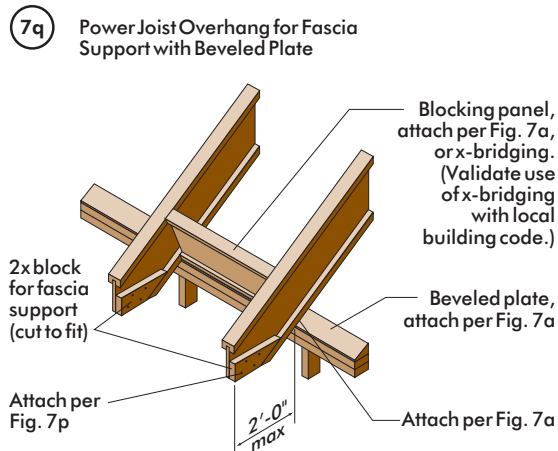
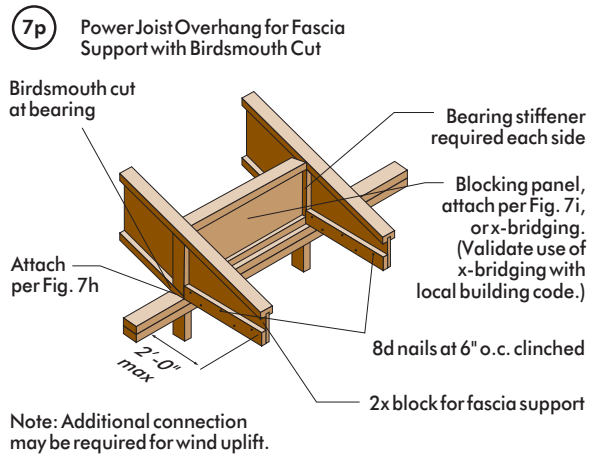

Note: Additional connection may be required for wind uplift.

Allowable Roof Spans—Simple Span

Snow Load LDF = 1.15

Notes:

1. Allowable clear span applicable to simple-span roof construction with 2' overhang. The live load deflection is limited to L/240 and total load deflection to L/180.
2. Spans are based on a duration of load (DOL) factor of 1.15.
3. Minimum bearing length must be 1-3/4" (44.5 mm) for the end bearings and 3-1/2" (89 mm) on end bearing adjacent to cantilever.
4. Bearing stiffeners are not required when Power Joists are used with the spans and spacings given in this table, except as required by hanger manufacturers.

Table 8										
Simple Span			Live Load = 20 psf			Dead Load = 15 psf				
Depth	Series	Slope of 1/4:12 to 4:12			Slope of 4:12 to 8:12			Slope of 8:12 to 12:12		
		16" oc	19.2" oc	24" oc	16" oc	19.2" oc	24" oc	16" oc	19.2" oc	24" oc
9-1/2"	ADI-40	21'-9"	19'-10"	17'-9"	20'-7"	19'-3"	17'-3"	19'-0"	17'-10"	16'-6"
	ADI-60	23'-4"	21'-11"	20'-3"	21'-11"	20'-7"	19'-0"	20'-2"	19'-0"	17'-7"
11-7/8"	ADI-40	25'-3"	23'-0"	20'-6"	24'-6"	22'-4"	19'-11"	22'-10"	21'-5"	19'-2"
	ADI-60	27'-11"	26'-3"	24'-2"	26'-3"	24'-8"	22'-10"	24'-3"	22'-9"	21'-1"
	ADI-80	31'-1"	29'-3"	27'-0"	29'-3"	27'-5"	25'-5"	27'-0"	25'-4"	23'-6"
14"	ADI-40	28'-0"	25'-6"	22'-9"	27'-2"	24'-9"	22'-1"	25'-11"	23'-9"	21'-3"
	ADI-60	31'-10"	29'-11"	26'-9"	29'-11"	28'-1"	26'-0"	27'-8"	25'-11"	24'-0"
	ADI-80	35'-5"	33'-3"	30'-9"	33'-3"	31'-3"	28'-11"	30'-8"	28'-10"	26'-9"
16"	ADI-40	30'-4"	27'-8"	24'-9"	29'-5"	26'-10"	24'-0"	28'-3"	25'-9"	23'-0"
	ADI-60	35'-5"	32'-6"	29'-1"	33'-3"	31'-3"	28'-2"	30'-8"	28'-10"	26'-9"
	ADI-80	39'-3"	36'-11"	34'-2"	36'-11"	34'-8"	32'-1"	34'-1"	32'-0"	29'-8"

Table 9										
Simple Span			Live Load = 25 psf			Dead Load = 15 psf				
Depth	Series	Slope of 1/4:12 to 4:12			Slope of 4:12 to 8:12			Slope of 8:12 to 12:12		
		16" oc	19.2" oc	24" oc	16" oc	19.2" oc	24" oc	16" oc	19.2" oc	24" oc
9-1/2"	ADI-40	20'-5"	18'-7"	16'-7"	19'-9"	18'-1"	16'-2"	17'-1"	15'-10"	14'-1"
	ADI-60	22'-3"	20'-11"	19'-4"	21'-0"	19'-8"	18'-3"	18'-2"	17'-0"	15'-9"
11-7/8"	ADI-40	23'-7"	21'-6"	19'-3"	23'-0"	20'-11"	18'-9"	20'-1"	18'-4"	16'-4"
	ADI-60	26'-9"	25'-1"	22'-7"	25'-2"	23'-8"	21'-10"	21'-9"	20'-5"	18'-11"
	ADI-80	29'-9"	27'-11"	25'-10"	28'-0"	26'-4"	24'-4"	24'-3"	22'-9"	21'-1"
14"	ADI-40	26'-2"	23'-10"	21'-4"	25'-6"	23'-3"	20'-9"	22'-3"	20'-4"	18'-2"
	ADI-60	30'-6"	28'-1"	25'-1"	28'-8"	26'-11"	24'-5"	24'-10"	23'-4"	21'-4"
	ADI-80	29'-9"	27'-11"	25'-10"	31'-11"	29'-11"	27'-8"	27'-7"	25'-11"	24'-0"
16"	ADI-40	28'-5"	25'-11"	23'-2"	27'-8"	25'-3"	22'-6"	24'-2"	22'-0"	19'-8"
	ADI-60	33'-5"	30'-5"	27'-2"	31'-11"	29'-8"	26'-6"	27'-7"	25'-11"	23'-2"
	ADI-80	37'-7"	35'-3"	32'-5"	35'-4"	33'-3"	30'-9"	30'-8"	28'-9"	26'-7"

Table 10										
Simple Span			Live Load = 30 psf			Dead Load = 15 psf				
Depth	Series	Slope of 1/4:12 to 4:12			Slope of 4:12 to 8:12			Slope of 8:12 to 12:12		
		16" oc	19.2" oc	24" oc	16" oc	19.2" oc	24" oc	16" oc	19.2" oc	24" oc
9-1/2"	ADI-40	19'-3"	17'-6"	15'-8"	18'-9"	17'-1"	15'-3"	15'-5"	14'-0"	12'-6"
	ADI-60	21'-5"	20'-1"	18'-5"	20'-2"	18'-11"	17'-6"	16'-9"	15'-8"	14'-6"
11-7/8"	ADI-40	22'-3"	20'-4"	18'-2"	21'-9"	19'-10"	17'-8"	17'-10"	16'-3"	14'-6"
	ADI-60	25'-8"	23'-11"	21'-4"	24'-3"	22'-9"	20'-10"	20'-1"	18'-10"	17'-1"
	ADI-80	28'-7"	26'-10"	24'-10"	27'-0"	25'-4"	23'-5"	22'-4"	21'-0"	19'-5"
14"	ADI-40	24'-8"	22'-6"	20'-1"	24'-1"	22'-0"	19'-8"	19'-9"	18'-0"	16'-1"
	ADI-60	29'-0"	26'-6"	23'-8"	27'-7"	25'-10"	23'-1"	22'-11"	21'-2"	18'-11"
	ADI-80	32'-6"	30'-6"	28'-2"	30'-8"	28'-10"	26'-8"	25'-5"	23'-10"	22'-1"
16"	ADI-40	26'-9"	24'-5"	21'-10"	26'-2"	23'-10"	21'-4"	21'-5"	19'-7"	17'-5"
	ADI-60	31'-6"	28'-9"	25'-8"	30'-8"	28'-1"	25'-1"	25'-2"	23'-0"	20'-6"
	ADI-80	36'-1"	33'-10"	30'-7"	34'-1"	32'-0"	29'-7"	28'-3"	26'-6"	24'-6"

Allowable Roof Spans—Simple Span

Snow Load LDF = 1.15

Table 11										
Simple Span Live Load = 40 psf Dead Load = 15 psf										
Depth	Series	Slope of 1/4:12 to 4:12			Slope of 4:12 to 8:12			Slope of 8:12 to 12:12		
		16" oc	19.2" oc	24" oc	16" oc	19.2" oc	24" oc	16" oc	19.2" oc	24" oc
9-1/2"	ADI-40	17'-5"	15'-10"	14'-2"	17'-1"	15'-7"	13'-11"	16'-7"	15'-2"	13'-6"
	ADI-60	20'-0"	18'-8"	16'-8"	18'-11"	17'-9"	16'-4"	17'-7"	16'-6"	15'-4"
11-7/8"	ADI-40	20'-2"	18'-4"	16'-5"	19'-9"	18'-0"	16'-1"	19'-3"	17'-6"	15'-8"
	ADI-60	23'-8"	21'-7"	19'-4"	22'-8"	21'-2"	18'-11"	21'-2"	19'-10"	18'-4"
	ADI-80	26'-8"	25'-0"	23'-0"	25'-3"	23'-8"	21'-11"	23'-7"	22'-1"	20'-5"
14"	ADI-40	22'-4"	20'-5"	18'-2"	21'-11"	20'-0"	17'-10"	21'-4"	19'-5"	17'-4"
	ADI-60	26'-3"	24'-0"	21'-5"	25'-9"	23'-6"	21'-0"	24'-1"	22'-8"	20'-5"
	ADI-80	30'-4"	28'-6"	25'-6"	28'-9"	27'-0"	24'-11"	26'-10"	25'-2"	23'-3"
16"	ADI-40	24'-3"	22'-1"	19'-9"	23'-9"	21'-8"	19'-4"	23'-2"	21'-1"	18'-10"
	ADI-60	28'-6"	26'-0"	23'-3"	27'-11"	25'-6"	22'-9"	26'-10"	24'-10"	22'-2"
	ADI-80	33'-8"	31'-0"	27'-7"	31'-11"	29'-11"	27'-2"	29'-9"	27'-11"	25'-10"

Table 12										
Simple Span Live Load = 50 psf Dead Load = 15 psf										
Depth	Series	Slope of 1/4:12 to 4:12			Slope of 4:12 to 8:12			Slope of 8:12 to 12:12		
		16" oc	19.2" oc	24" oc	16" oc	19.2" oc	24" oc	16" oc	19.2" oc	24" oc
9-1/2"	ADI-40	16'-0"	14'-7"	13'-0"	15'-9"	14'-4"	12'-10"	15'-5"	14'-0"	12'-6"
	ADI-60	18'-9"	17'-2"	15'-4"	17'-11"	16'-9"	15'-1"	16'-9"	15'-8"	14'-6"
11-7/8"	ADI-40	18'-6"	16'-11"	15'-1"	18'-3"	16'-7"	14'-10"	17'-10"	16'-3"	14'-6"
	ADI-60	21'-10"	19'-11"	17'-9"	21'-5"	19'-7"	17'-6"	20'-1"	18'-10"	17'-1"
	ADI-80	25'-1"	23'-6"	21'-2"	23'-11"	22'-5"	20'-9"	22'-4"	21'-0"	19'-5"
14"	ADI-40	20'-7"	18'-9"	16'-9"	20'-3"	18'-5"	16'-6"	19'-9"	18'-0"	16'-1"
	ADI-60	24'-2"	22'-1"	19'-8"	23'-9"	21'-8"	19'-4"	22'-11"	21'-2"	18'-11"
	ADI-80	28'-6"	26'-3"	23'-4"	27'-2"	25'-6"	23'-1"	25'-5"	23'-10"	22'-1"
16"	ADI-40	22'-4"	20'-4"	18'-2"	21'-11"	20'-0"	17'-10"	21'-5"	19'-7"	17'-5"
	ADI-60	26'-3"	23'-11"	21'-4"	25'-10"	23'-6"	21'-0"	25'-2"	23'-0"	20'-6"
	ADI-80	31'-3"	28'-6"	23'-4"	30'-2"	28'-0"	25'-1"	28'-3"	26'-6"	24'-6"

Notes:

1. Allowable clear span applicable to simple-span roof construction with 2' overhang. The live load deflection is limited to L/240 and total load deflection to L/180.
2. Spans are based on a duration of load (DOL) factor of 1.15.
3. Minimum bearing length must be 1-3/4" (44.5 mm) for the end bearings and 3-1/2" (89 mm) on end bearing adjacent to cantilever.
4. Bearing stiffeners are not required when Power Joists are used with the spans and spacings given in this table, except as required by hanger manufacturers.

Allowable Roof Spans—Multiple Span Flat Roof 1/4-12

Table 13				
Multiple Span				
		Live Load = 20 psf	Dead Load = 15 psf	
Depth	Designation	16" oc	19.2" oc	24" oc
9-1/2"	ADI-40	22'-1"	20'-2"	18'-0"
	ADI-60	25'-11"	23'-8"	21'-2"
11-7/8"	ADI-40	25'-6"	23'-4"	20'-10"
	ADI-60	30'-0"	27'-5"	24'-6"
	ADI-80	34'-11"	32'-7"	29'-2"
14"	ADI-40	28'-4"	25'-10"	23'-1"
	ADI-60	33'-3"	30'-4"	27'-2"
	ADI-80	39'-7"	36'-2"	32'-4"
16"	ADI-40	30'-9"	28'-0"	25'-0"
	ADI-60	36'-1"	32'-11"	29'-5"
	ADI-80	43'-0"	39'-3"	35'-1"

Table 14				
Multiple Span				
		Live Load = 25 psf	Dead Load = 15 psf	
Depth	Designation	16" oc	19.2" oc	24" oc
9-1/2"	ADI-40	20'-8"	18'-10"	16'-10"
	ADI-60	24'-3"	22'-1"	19'-9"
11-7/8"	ADI-40	23'-10"	21'-9"	19'-5"
	ADI-60	28'-1"	25'-7"	22'-11"
	ADI-80	33'-4"	30'-6"	27'-3"
14"	ADI-40	26'-6"	24'-2"	21'-7"
	ADI-60	31'-1"	28'-5"	25'-4"
	ADI-80	37'-1"	33'-10"	30'-3"
16"	ADI-40	28'-9"	26'-2"	23'-5"
	ADI-60	33'-9"	30'-9"	27'-6"
	ADI-80	40'-2"	36'-8"	32'-9"

Table 15				
Multiple Span				
		Live Load = 30 psf	Dead Load = 15 psf	
Depth	Designation	16" oc	19.2" oc	24" oc
9-1/2"	ADI-40	19'-5"	17'-9"	15'-10"
	ADI-60	22'-10"	20'-10"	18'-7"
11-7/8"	ADI-40	22'-6"	20'-6"	18'-4"
	ADI-60	26'-5"	24'-2"	21'-7"
	ADI-80	31'-6"	28'-9"	25'-8"
14"	ADI-40	24'-11"	22'-9"	20'-4"
	ADI-60	29'-4"	26'-9"	23'-11"
	ADI-80	34'-11"	31'-10"	28'-6"
16"	ADI-40	27'-1"	24'-8"	22'-1"
	ADI-60	31'-10"	29'-0"	25'-4"
	ADI-80	37'-11"	34'-7"	30'-8"

Table 16				
Multiple Span				
		Live Load = 40 psf	Dead Load = 15 psf	
Depth	Designation	16" oc	19.2" oc	24" oc
9-1/2"	ADI-40	17'-7"	16'-0"	14'-4"
	ADI-60	20'-8"	18'-10"	16'-10"
11-7/8"	ADI-40	20'-4"	18'-6"	16'-7"
	ADI-60	23'-11"	21'-10"	19'-6"
	ADI-80	28'-6"	26'-0"	22'-10"
14"	ADI-40	22'-7"	20'-7"	18'-4"
	ADI-60	26'-6"	24'-2"	20'-8"
	ADI-80	31'-7"	28'-10"	25'-0"
16"	ADI-40	24'-5"	22'-4"	19'-11"
	ADI-60	28'-9"	25'-11"	20'-8"
	ADI-80	34'-3"	31'-3"	25'-0"

Notes:

1. Allowable clear span applicable to multiple-span roof construction with a 2' overhang. The end spans must be 40% or more of the adjacent span. The live load deflection is limited to span/240 and total load deflection to span/180.
2. Spans are based on a duration of load (DOL) factor of 1.15.
3. Minimum bearing length must be 1-3/4" (44.5 mm) for the end bearings, and 3-1/2" (89 mm) for the intermediate bearing.
4. Bearing stiffeners are not required when ADI Power Joists are used with the spans and spacings given in this table, except as required by hanger manufacturers.

Allowable Roof Uniform Load Capacities

Table 17

ADI Power Joist — ADI 40 Allowable uniform loads (PLF) Roof

CLEAR JOIST SPAN (ft.)	9-1/2"			11-7/8"			14"			16"		
	LIVE LOAD	TOTAL LOAD		LIVE LOAD	TOTAL LOAD		LIVE LOAD	TOTAL LOAD		LIVE LOAD	TOTAL LOAD	
		Defl. L/240	SNOW 115%		NON- SNOW 125%	Defl. L/240		SNOW 115%	NON- SNOW 125%		Defl. L/240	SNOW 115%
6		323	351		374	407		374	407		374	407
7		278	302		322	336		322	336		322	336
8		244	265		282	295		282	295		282	295
9		217	236		251	262		251	262		251	262
10		196	213		227	237		227	237		227	237
11		178	194		206	215		206	215		206	215
12		153	166		189	198		189	198		189	198
13		130	142		174	183		175	183		175	183
14		113	122		150	163		163	170		163	170
15		98	107		131	143		152	158		152	158
16		86	94		115	125		142	149		142	149
17		77	83		102	111		134	140		134	140
18		68	74		91	99		120	130		127	132
19	61	61	67		82	89		108	117		118	125
20	52	56	60		74	81		97	106		107	116
21	45	50	55		67	73		88	96		97	105
22	39	46	50		61	67		81	88		88	96
23	34	42	46		56	61		74	80		81	88
24	30	39	41		52	56		68	74		74	81
25	27	36	36	46	48	52		62	68		69	75
26		32	32	41	44	48		58	63		63	69
27		29	29	37	41	44	53	54	58		59	64
28		26	26	33	38	41	48	50	54		55	60
29				30	35	39	43	47	51		51	56
30				27	33	36	39	43	47		48	52
31					31	32	35	41	44		45	49
32					29	29	32	38	42		42	46
33					27	27	29	36	39		39	43
34							27	34	36	37	37	40

Notes:

1. Roof joists must be sloped a minimum of 1/4" in 12".
2. Live Load column limits deflection to L/240, Total Load column limits deflection to L/180.
Cathedral ceilings or sheet rocked rafters may require stiffer performance or additional design.
3. Values represent the most restrictive of simple span or multiple span conditions.
4. Values are for Power Joists spaced at a maximum of 24" on center.
5. Table assumes a minimum end bearing length of 1-3/4" and a minimum interior bearing length of 3-1/2"
6. Web stiffeners are not required except when the joist hangers do not provide lateral support for the top flange of the Power Joists. Web stiffeners are required at birdsmouth cuts and when required by hanger manufacturers for proper connections.

Joist Sizing:

1. Select desired joist depth (column).
2. Select desired span (row).
3. Check BOTH Live Load and Total Load columns.
4. If Live Load column is blank, Total Load capacity governs.

Allowable Roof Uniform Load Capacities

Table 18

ADI Power Joist — ADI 60 Allowable uniform loads (PLF) Roof

CLEAR JOIST SPAN (ft.)	9-1/2"			11-7/8"			14"			16"		
	LIVE LOAD	TOTAL LOAD		LIVE LOAD	TOTAL LOAD		LIVE LOAD	TOTAL LOAD		LIVE LOAD	TOTAL LOAD	
		Defl. L/240	SNOW 115%		NON- SNOW 125%	Defl. L/240		SNOW 115%	NON- SNOW 125%		Defl. L/240	SNOW 115%
6		323	351		374	407		374	407		374	407
7		278	302		322	336		322	336		322	336
8		244	265		282	295		282	295		282	295
9		217	236		251	262		251	262		251	262
10		196	213		227	237		227	237		227	237
11		178	194		206	215		206	215		206	215
12		164	178		189	198		189	198		189	198
13		151	164		175	183		175	183		175	183
14		140	153		163	170		163	170		163	170
15		131	143		152	158		152	158		152	158
16		119	129		142	149		142	149		142	149
17	101	106	115		134	140		134	140		134	140
18	85	94	102		126	132		127	132		127	132
19	73	85	92		113	123		120	125		120	125
20	62	77	83		102	111		114	119		114	119
21	54	69	72	92	93	101		109	113		109	113
22	47	63	63	81	85	92		104	108		104	108
23	41	55	55	71	77	84		95	103		99	104
24	36	48	48	62	71	77		87	95		95	99
25	32	43	43	55	66	71		81	88		91	95
26	29	38	38	49	61	65	72	74	81		87	92
27	26	34	34	44	56	58	65	69	75		81	88
28		31	31	39	52	52	58	64	70		75	82
29		28	28	35	47	47	52	60	65		70	77
30				32	43	43	47	56	61	65	66	72
31				29	39	39	43	52	57	59	62	67
32				26	35	35	39	49	52	53	58	63
33					32	32	36	46	47	49	54	59
34					29	29	32	43	43	44	51	56

Notes:

1. Roof joists must be sloped a minimum of 1/4" in 12".
2. Live Load column limits deflection to L/240, Total Load column limits deflection to L/180. Cathedral ceilings or sheet rocked rafters may require stiffer performance or additional design.
3. Values represent the most restrictive of simple span or multiple span conditions.
4. Values are for Power Joists spaced at a maximum of 24" on center.
5. Table assumes a minimum end bearing length of 1-3/4" and a minimum interior bearing length of 3-1/2"
6. Web stiffeners are not required except when the joist hangers do not provide lateral support for the top flange of the Power Joists. Web stiffeners are required at birdsmouth cuts and when required by hanger manufacturers for proper connections.

Joist Sizing:

1. Select desired joist depth (column).
2. Select desired span (row).
3. Check BOTH Live Load and Total Load columns.
4. If Live Load column is blank, Total Load capacity governs.

Allowable Roof Uniform Load Capacities

Table 19

ADI Power Joist — ADI 80 Allowable uniform loads (PLF) Roof

CLEAR JOIST SPAN (ft.)	11-7/8"			14"			16"		
	LIVE LOAD	TOTAL LOAD		LIVE LOAD	TOTAL LOAD		LIVE LOAD	TOTAL LOAD	
		Defl. L/240	SNOW 115%		NON- SNOW 125%	Defl. L/240		SNOW 115%	NON- SNOW 125%
6		413	449		452	491		452	491
7		355	358		389	358		389	358
8		312	314		341	314		341	314
9		278	280		304	280		304	280
10		250	252		274	252		274	252
11		228	230		249	230		249	230
12		209	211		229	211		229	211
13		193	195		211	195		211	195
14		180	181		196	181		196	181
15		168	169		183	169		183	169
16		157	159		172	159		172	159
17		148	149		162	149		162	149
18		140	141		153	141		153	141
19		133	134		145	134		145	134
20		126	127		138	127		138	127
21		120	121		131	121		131	121
22	111	115	116		125	116		125	116
23	97	109	111		120	111		120	111
24	86	101	106		115	106		115	106
25	76	93	101		110	102		110	102
26	68	86	90	99	105	98		106	98
27	60	80	81	89	98	94		102	94
28	54	72	72	79	91	91		99	91
29	49	65	65	72	85	88		95	88
30	44	59	59	65	79	85	88	92	85
31	40	53	53	59	74	78	80	87	82
32	36	49	49	53	70	71	73	82	80
33	33	44	44	49	65	65	66	77	77
34	30	41	41	45	59	59	61	73	75

Notes:

1. Roof joists must be sloped a minimum of 1/4" in 12".
2. Live Load column limits deflection to L/240, Total Load column limits deflection to L/180. Cathedral ceilings or sheet rocked rafters may require stiffer performance or additional design.
3. Values represent the most restrictive of simple span or multiple span conditions.
4. Values are for Power Joists spaced at a maximum of 24" on center.
5. Table assumes a minimum end bearing length of 1-3/4" and a minimum interior bearing length of 3-1/2"
6. Web stiffeners are not required except when the joist hangers do not provide lateral support for the top flange of the Power Joists. Web stiffeners are required at birdsmouth cuts and when required by hanger manufacturers for proper connections.

Joist Sizing:

1. Select desired joist depth (column).
2. Select desired span (row).
3. Check BOTH Live Load and Total Load columns.
4. If Live Load column is blank, Total Load capacity governs.

Multiple Power Joist™ Construction

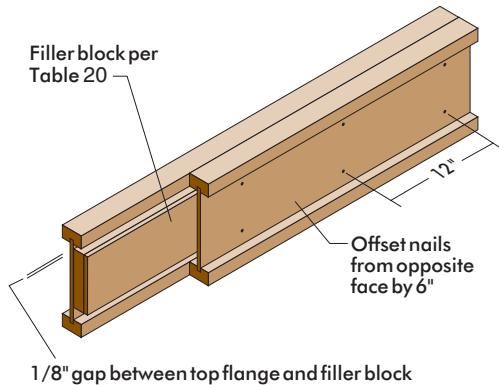

Table 20

Filler Block Requirements for Double Power Joist Construction

Flange Width	Net Depth	Joist Designation	Filler Block Size
2-1/2"	9-1/2"	ADI-40, ADI-60	2-1/8" x 6"
	11-7/8"	ADI-40, ADI-60	2-1/8" x 8"
	14"	ADI-60	2-1/8" x 10"
	16"	ADI-60	2-1/8" x 12"
3-1/2"	11-7/8"	ADI-80	3" x 8"
	14"	ADI-80	3" x 10"
	16"	ADI-80	3" x 12"

Notes:

1. Support back of I-joist web during nailing to prevent damage to web/flange connection.
2. Leave a 1/8" gap between top of filler block and bottom of top I-joist flange.
3. Filler block is required between joists for full length of span.
4. Nail joists together with two rows of 10d nails at 12" o.c. (clinched when possible) on each side of the double I-joist. Total of 4 nails per foot required. If nails can be clinched, only 2 nails per foot are required.

Power Joist™ Web Stiffeners

A web stiffener is a plywood, OSB or wood block that is used to reinforce the web of a Power Joist, increase bearing area, and add support for hangers or other connectors where:

- The webs of the Power Joists are in jeopardy of buckling out of plane. This usually occurs in deeper Power Joists.
- The webs of the Power Joist are in jeopardy of “knifing” through the Power Joist flanges. This can occur at any Power Joist depth when the concentrated loads entering the joist, or the reaction loads exiting the joist exceed a specific level.
- The Power Joist is supported in a hanger and the sides of the hanger do not extend up to the top flange. With the top flange unsupported by the hanger sides, the joist may deflect laterally, putting a twist in the flange of the joist. The web stiffener supports the Power Joist along a vertical

axis as designed. (In this application, the web stiffener acts very much like a backer block.)

There are two types of web stiffeners designed to transfer load into and out of a Power Joist, bearing stiffeners and load stiffeners. They are differentiated by the location of the load transfer and the location of the gap between the slightly undersized stiffener and the top or bottom flange.

A load stiffener is required at locations where a concentrated load exceeds 1500 lb. and is applied to the top flange between supports, or in the case of a cantilever, anywhere between the end of the cantilever and the support. The stiffener is applied tight to the bottom of the top flange, gap at the bottom.

When used at mid-span or end joist bearing locations, bearing stiffeners are applied tight to the top of the bottom flange, gap at the top.

Web Stiffener Size Requirements

ADI Flange Width	Web Stiffener Size Each Side of Web
2-1/2"	1" x 2-5/16" minimum width
3-1/2"	1-1/2" x 2-5/16" minimum width

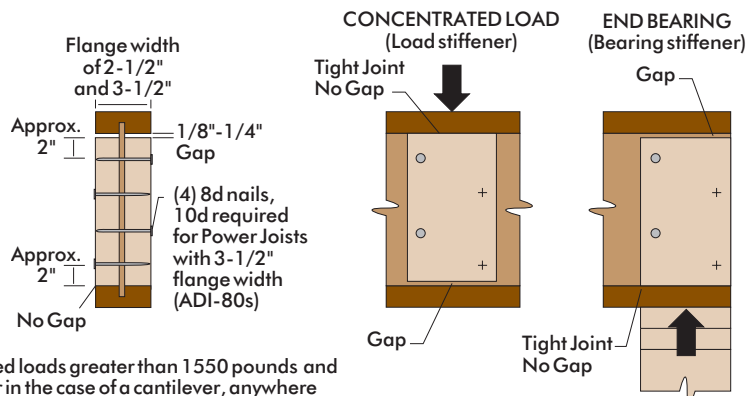

Notes:

1. Web stiffeners shall be installed at bearing points.
2. Web stiffeners shall be installed at points of concentrated loads greater than 1550 pounds and are to be applied to the top flange between supports, or in the case of a cantilever, anywhere between the end of the cantilever and the support.
3. Web stiffeners are to be installed on each side of the web as shown above.
4. Web stiffener material shall be sheathing complying with the requirements of PS-1 or PS-2 with the face grain parallel to the long axis.

Power Joist™ Design Properties

Table 21 Power Joist Design Properties ⁽¹⁾

Joist Depth	Joist Designation	Moment Deflection Factor EI ⁽²⁾ 10 ⁶ lbf-in ²	Moment Capacity M (lbf x ft)	Shear Capacity V (lbf)	Intermediate Reaction ² IR (lbf)	End Reaction ³ ER (lbf)	Shear Deflection Factor K x 10 ⁶ (lbf)
9-1/2"	ADI-40	193	2,355	1,120	2,160	1,080	4.94
	ADI-60	231	3,245	1,120	2,160	1,080	4.94
11-7/8"	ADI-40	330	3,145	1,420	2,500	1,200	6.18
	ADI-60	396	4,335	1,420	2,500	1,200	6.18
	ADI-80	547	6,130	1,420	2,760	1,280	6.18
14"	ADI-40	482	3,860	1,710	2,500	1,200	7.28
	ADI-60	584	5,320	1,710	2,500	1,200	7.28
	ADI-80	802	7,525	1,710	3,020	1,280	7.28
16"	ADI-40	657	4,535	1,970	2,500	1,200	8.32
	ADI-60	799	6,250	1,970	2,500	1,200	8.32
	ADI-80	1,092	8,845	1,970	3,020	1,280	8.32

SI: 1 inch = 25.4 mm; 1 lbf = 4.45 kN, 1 lbf.ft. = 1.356 N-m, 1 lbf.in² = 0.00287 N-m²,

- (1) Values are design values for normal duration of loads. All values, except for EI and K, are permitted to be adjusted for other load durations as permitted by the applicable code for solid sawn lumber.
- (2) Intermediate Reaction (IR) with a minimum bearing length of 3-1/2 inches without bearing stiffeners.
- (3) End reaction (ER) for simple spans with a minimum bearing length of 1-3/4 inches without web stiffeners. For a bearing length of 4 inches the end reaction may be set equal to the tabulated shear value. Interpolation of the end reaction between 1-3/4 inches and 4 inch bearing is permitted. For end reaction values over 1 550 lbf, web stiffeners are required.
- (4) For calculating uniform load and center-point load deflection of the Power Joist in a simple span application:

$$\text{For Uniform Load: } \Delta = \frac{5wl^4}{384EI} + \frac{wl^2}{K} \quad [1]$$

$$\text{For Center-Point Load: } \Delta = \frac{Pl^3}{48EI} + \frac{2Pl}{K} \quad [2]$$

Where: Δ = calculated deflection (in)
 w = uniform load (lbf/in)
 l = design span (in)
 P = concentrated load (lbf)
 EI = bending stiffness of the I-joist (lbf-in²)
 K = coefficient of shear deflection (lbf)

Certified Rim Board

A rim board is the wood component that fills the space between the sill plate and bottom surface of the sheathing, or in second floor construction, between the top plate and bottom surface of the floor sheathing under the second floor wall.

These rim boards have less shrinkage than lumber and match the depth of wood I-joists and other engineered wood framing products. They are available in lengths up to 24'.

As glued engineered wood products, rim boards have greater dimensional stability, higher strength, increased structural reliability, more consistent quality and lower tendency to check or split than sawn lumber.

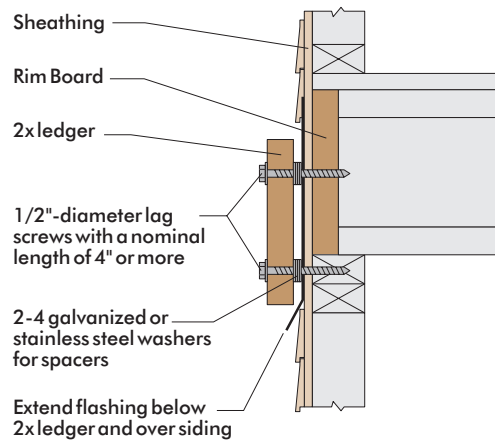
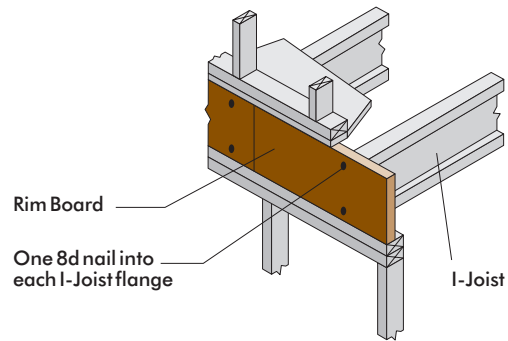

Note: This schematic drawing is a construction detail recommended for attachment of a ledger in order to avoid potential decay problems on either the ledger or other building components. After placing flashing, temporarily hang 2x ledger. Drill clearance and lead holes, remove 2x ledger, caulk holes with high quality caulking, immediately reapply 2x ledger and install the lag screws.

Table 22

Standard Sizes

Rim Board is available in the following dimension:

	Standard Sizes
Thickness (inches)	1 - 1/8 , 1 - 1/4
Depth (inches)	9 - 1/2 , 11 - 7/8 , 14 , 16
Length (feet)	12 , 16 , 24

Table 23

Capacities

Certified Rated Rim Boards have the following design capacities ⁽¹⁾:

Grade	t _{min} ⁽²⁾ (in.)	H ⁽³⁾ (lbf/ft.)	V ⁽⁴⁾ (lbf/ft.)	Z ⁽⁵⁾ (lbf)	P ⁽⁶⁾ (lbf)
		Depth (d) Limitation (in.)			
		d ≤ 16	d ≤ 16	d ≤ 16	d ≤ 16
Rim Board	1 - 1/8	180	4,400	350	3,500
Rim Board Plus	1 - 1/8	200	5,700	350	3,500

(1) These design values are applicable only to rim board applications in compliance with the connection requirements given in this document and should not be used in the design of a bending member, such as a joist, header, rafter, or ledger. The design values are applicable to the normal load duration (10 years) for wood products, except for the horizontal load transfer capacity, which is based on the short-term load duration (10 minutes). All values may be adjusted for other load durations in accordance with the applicable code.

(2) Minimum thickness for design capacities listed.

(3) The horizontal (shear) load transfer capacity.

(4) The bearing (vertical) load capacity.

(5) The lateral resistance of a 1/2"-diameter lag screw.

(6) The concentrated load capacity, which must be satisfied simultaneously with the bearing load capacity (V).

Power Joist™ Framing Connectors

Table 24

Simpson Strong-Tie Hangers for ADI 40, 60 & 80 Series

Power Joist		Simpson Strong-Tie Hangers																
Width	Depth	Top Mount	Load				Snap-In	Load			Face Mount	Load			Skewed 45	Load		
			Uplift (133)	DF/SP	SPF	SPF		Uplift (133)	DF/SP	SPF		Uplift (133)	DF/SP	SPF		Uplift (133)	DF/SP	SPF
2-1/2	9-1/2	ITT39.5	245	1615	1200	IUS2.56/9.5	75	895	775	IUT310	245	890	770	SUR/L310	720	1860	1610	
	11-7/8	ITT311.88	245	1615	1200	IUS2.56/11.88	75	895	775	IUT312	245	1110	960	SUR/L310	720	1860	1610	
	14	ITT314	245	1615	1200	IUS2.56/14	75	1345	1160	IUT314	245	1555	1345	SUR/L314	960	2395	1795	
	16	ITT316	245	1615	1200	IUS2.56/16	75	1570	1350	IUT316	245	1775	1535	SUR/L314	960	2395	1795	
3-1/2	9-1/2	ITT49.5	245	1615	1200	No IUS for this depth			IUT410	245	890	770	SUR/L410	720	1860	1610		
	11-7/8	ITT411.88	245	1615	1200	IUS3.56/11.88	75	1120	970	IUT412	245	1110	960	SUR/L410	720	1860	1610	
	14	ITT414	245	1615	1200	IUS3.56/14	75	1345	1150	IUT414	245	1555	1345	SUR/L414	960	2395	1795	
	16	ITT416	245	1615	1200	IUS3.56/16	75	1570	1350	IUT416	245	1775	1535	SUR/L414	960	2395	1795	

Notes:

1. Shaded hangers require web stiffeners. Web stiffeners may be required for non-shaded hangers by Anthony-Domtar.
2. This table is for quick specification for Power Joist hangers. Refer to hanger manufacturer for additional design information.

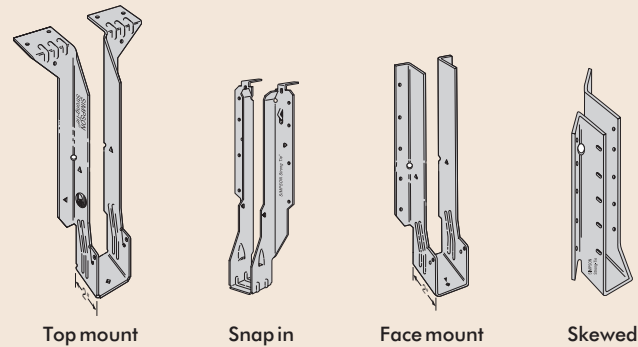

Table 25

USP Hangers for ADI 40, 60 & 80 Series

Power Joist		USP Lumber Connectors											
Width	Depth	Top Mount	Load			Face Mount	Load			Skewed 45	Load		
			Uplift (133)	DF/SP	SPF		Uplift (133)	DF/SP	SPF		Uplift (133)	DF/SP	SPF
2-1/2	9-1/2	THO25950	245	1625	1625	THF25925	175	1345	1345	SKH2520L/SKH2520R	1305	1580	1360
	11-7/8	THO25118	245	1835	1835	THF25112	175	1570	1570	SKH2520L/SKH2520R	1305	1580	1360
	14	THO25140	245	2375	2375	THF25140	175	2025	2025	SKH2524L/SKH2524R	1305	1810	1550
	16	THO25160	245	2375	2375	THF25160	175	2475	2475	SKH2524L/SKH2524R	1305	1810	1550
3-1/2	11-7/8	THO35118	245	2050	2050	THF35112	245	1795	1795	SKH410L/SKH410R	1345	2175	1855
	14	THO35140	245	2715	2715	THF35140	245	2250	2250	SKH414L/SKH414R	1345	2990	2550
	16	THO35160	245	2715	2715	THF35157	245	2475	2475	SKH414L/SKH414R	1345	2990	2550

Notes:

1. Shaded hangers require web stiffeners. Web stiffeners may be required for non-shaded hangers by Anthony-Domtar.
2. This table is for quick specification for Power Joist hangers. Refer to hanger manufacturer for additional design information.

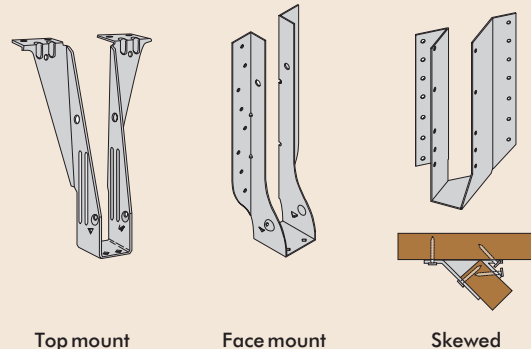

Anthony Power Sizer™ 2002 Software



Anthony Power Sizer™ from Anthony Forest Products Company is a sizing program for all Anthony Power Products. This includes all glulam beams and Power Joist™. This Windows based program is simple to use and provides for flexible analysis and design of Power Joist™ and Power Beam® for a variety of roof and floor applications.

The Anthony Power Sizer™ is a software program that lets you enter your span, load and hole information from specifications or drawings. The interactive graphics are included in the printed design output and directly replicate the sizing input by displaying supports, loads, holes and simple or multiple spans. Based on joist loading requirements, Power Sizer™ will provide you with multiple product solutions based on product series, depth and on center spacing of Power Joist™.

An easy-to-read design calculation can be printed for submission to local building officials. The output provides a representation of the loading conditions and analysis information. At a glance, the relative performance of Anthony Power Joist against your design standards can be determined. A comprehensive help file menu is also included in the program.

The Power Sizer™ is available to architects, engineers and designers. Hardware requirements include Pentium® processor with minimum of 32 Mb of RAM. To order software, contact the Anthony Forest Products sales office or download it from our website, www.anthonyforest.com

Power Products Warranty

Limited Lifetime Warranty

Anthony Forest Products Company warrants that its Power Joist™, Power Beam®, Power Header®, Power Log®, and Power Plank® are free from defects in design, materials and workmanship. When installed and finished according to our published installation instructions and accepted engineering standards, our Power Products will perform in accordance with our current published specifications for the lifetime of your home or building.

Warranty Limitations

Anthony Forest Products Company must be given a reasonable opportunity to inspect the product before it will honor any claims under this warranty. If after inspection and verification of the problem, we determine that there is a structural failure covered by the warranty, we will pay to the owner of the structure an amount of money equal to the reasonable cost of labor and materials required to remove and replace or repair the defective product, or, at our option, repair or replace any defective product. Checks, cracks or splits of Power Products resulting from the natural physical properties of wood are not covered — unless the condition causes a structural weakness.

Please protect your investment! Power Products must be protected from exposure to moisture from whatever source by proper building standards. Exposure to moisture beyond incidental exposure during normal construction periods may cause product failure and will void this limited warranty.

This warranty shall apply only if the Power Product is subjected to normal use and exposure. The products must be stored, handled, and installed in a manner generally accepted in the industry, and in accordance with our current published installation instructions and in compliance with our product design specifications relating to spans and loading. Failure to follow such instructions will void this warranty.

Disclaimer

EXCEPT FOR THE EXPRESS WARRANTY AND REMEDY SET FORTH ABOVE, ANTHONY FOREST PRODUCTS COMPANY DISCLAIMS ALL OTHER WARRANTIES AND GUARANTEES, EXPRESS OR IMPLIED, INCLUDING IMPLIED WARRANTIES OF MERCHANTABILITY OR FITNESS FOR A PARTICULAR PURPOSE. No other warranty or guarantee will be made by or on behalf of the manufacturer or the seller or by operation of law with respect to the product or its installation, storage, handling, maintenance, use, replacement, or repair. Neither Anthony Forest Products Company nor the seller shall be liable by virtue of any warranty or guarantee, or otherwise, for any special or incidental or consequential loss or damage resulting from the use of the product. Anthony Forest Products Company makes no warranty or guarantee with respect to installation of the product by the builder or the builder's contractor or by any other installer.

This warranty gives you specific legal rights and you may also have other rights which vary from state to state.

For information on the Power Products or our warranty, contact us at:

Anthony Forest Products Company
P.O. Box 1877,
El Dorado, Arkansas 71731
1-800-221 BEAM (2326)



POWER BEAM®



POWER COLUMN®



POWER LOG®



POWER PLANK®



POWER HEADER®

Call Anthony Forest Products for our complete family of Power Products to complete your building system.



Sales:

Anthony Forest Products Co.
309 North Washington
El Dorado, Arkansas
USA 71730
1-800 221-2326
Fax: 870 862-6502
info@anthonyforest.com
www.anthonyforest.com
www.anthonydomtar.com

Plant:

Anthony-Domtar Inc.
1195 Peoples Road
Sault Ste. Marie, Ontario
Canada P6C 3W6

Distributed by: